



# GRAPHIC SWITCHER II™ (GSW2811R)

## User's Manual

### TABLE OF CONTENTS

SAFETY INSTRUCTIONS .....	2
Chapter 1 : INTRODUCTION .....	5
Chapter 2 : INSTALLATION .....	6
Chapter 3 : TECHNICAL DESCRIPTION.....	7
Chapter 4 : STARTING .....	9
Chapter 5 : OPERATING MODE.....	12
Chapter 6 : LCD SCREEN DESCRIPTION .....	16
Chapter 7 : LCD FUNCTIONS DESCRIPTION .....	19
Chapter 8 : UPDATING THE GRAPHIC SWITCHER II™ .....	28
Chapter 9 : CONTROL SOFTWARE.....	29
Chapter 10 : RS-232 PROGRAMMER'S GUIDE .....	34
Chapter 11 : TECHNICAL SPECIFICATIONS .....	41
WARRANTY .....	44

## **SAFETY INSTRUCTIONS**

All of the safety and operating instructions should be read before the product is operated and should be retained for further reference. Please follow all of the warnings on this product and its operating instructions.

### **CAUTION :**

**WARNING:** To prevent the risk of electric shock and fire, do not expose this device to rain, humidity or intense heat sources (such as heaters or direct sunlight). Slots and openings in the device are provided for ventilation and to avoid overheating. Make sure the device is never placed on or near a textile surface that could block the openings. Also keep away from excessive dust, vibrations and shocks.

**POWER:** Only use the power supply indicated on the device or on the power source. Devices equipped with a grounding plug should only be used with a grounding type outlet. In no way should this grounding be modified, avoided or suppressed.

**POWER CORD:** Use the On (I) / Off (O) switch to power On or Off devices equipped with that switch. All other devices should be plugged and unplugged from wall outlet. In both cases, please follow these instructions:

- The power cord of the device should be unplugged from the outlet when left unused for several days.
- To unplug the device, do not pull on the power cord but always on the plug itself.
- The outlet should always be near the device and easily accessible.
- Power supply cords should be routed so that they are not likely to be walked on or pinched by items placed upon or against them.

If the power supply cord is damaged, unplug the device. Using the device with a damaged power supply cord may expose you to electric shocks or other hazards. Verify the condition of the power supply cords once in a while. Contact your dealer or service center for replacement if damaged.

**CONNECTIONS:** All inputs and outputs (except for the power input) are TBTS defined under EN60950.

**SERVICING:** Do not attempt to service this product yourself by opening or removing covers and screws since it may expose you to electric shocks or other hazards. Refer all problems to qualified service personnel.

**OPENINGS:** Never push objects of any kind into this product through the openings. If liquids have been spilled or objects have fallen into the device, unplug it immediately and have it checked by a qualified technician.

## **INSTRUCTIONS DE SÉCURITÉ:**

Afin de mieux comprendre le fonctionnement de cet appareil nous vous conseillons de bien lire toutes les consignes de sécurité et de fonctionnement de l'appareil avant utilisation. Conserver les instructions de sécurité et de fonctionnement afin de pouvoir les consulter ultérieurement. Respecter toutes les consignes marquées dans la documentation, sur le produit et sur ce document.

**ATTENTION :** Afin de prévenir tout risque de choc électrique et d'incendie, ne pas exposer cet appareil à la pluie, à l'humidité et aux sources de chaleur intense.

**INSTALLATION :** Veillez à assurer une circulation d'air suffisante pour éviter toute surchauffe à l'intérieur de l'appareil. Ne placez pas l'appareil sur ou proximité de surface textile susceptible d'obstruer les orifices de ventilation. N'installez pas l'appareil à proximité de sources de chaleur comme un radiateur ou une bouche d'air chaud, ni dans un endroit exposé au rayonnement solaire direct, à des poussières excessives, à des vibrations ou à des chocs mécaniques. Ceci pourrait provoquer un mauvais fonctionnement et un accident.

**ALIMENTATION :** Ne faire fonctionner l'appareil qu'avec la source d'alimentation indiquée sur l'appareil ou sur son bloc alimentation. Pour les appareils équipés d'une alimentation principale avec fil de terre, ils doivent être obligatoirement connectés sur une source équipée d'une mise à la terre efficace. En aucun cas cette liaison de terre ne devra être modifiée, contournée ou supprimée.

**CORDON D'ALIMENTATION :** Pour les appareils équipés d'un interrupteur général (Marche I / Arrêt O), la mise sous tension et la mise hors tension se fait en actionnant cet interrupteur général. Pour les appareils sans interrupteur général, la mise sous tension et la mise hors tension se fait directement en connectant et déconnectant le cordon d'alimentation de la prise murale.

Dans les 2 cas ci-dessus appliquer les consignes suivantes :

- Débrancher le cordon d'alimentation de la prise murale si vous prévoyez de ne pas utiliser l'appareil pendant quelques jours ou plus.
- Pour débrancher le cordon, tirez le par la fiche. Ne tirez jamais sur le cordon proprement dit.
- La prise d'alimentation doit se trouver à proximité de l'appareil et être aisément accessible.
- Ne laissez pas tomber le cordon d'alimentation et ne posez pas d'objets lourds dessus.

Si le cordon d'alimentation est endommagé, débranchez le immédiatement de la prise murale. Il est dangereux de faire fonctionner cet appareil avec un cordon endommagé, un câble abîmé peut provoquer un risque d'incendie ou un choc électrique. Vérifier le câble d'alimentation de temps en temps. Contacter votre revendeur ou le service après vente pour un remplacement.

**CONNEXIONS :** Toutes les entrées et sorties (exceptée l'entrée secteur) sont de type TBTS (Très Basse Tension de Sécurité) définies selon EN 60950.

**RÉPARATION ET MAINTENANCE :** L'utilisateur ne doit en aucun cas essayer de procéder aux opérations de dépannage, car l'ouverture des appareils par retrait des capots ou de toutes autres pièces constituant les boîtiers ainsi que le dévissage des vis apparentes à l'extérieur, risque d'exposer l'utilisateur à des chocs électriques ou autres dangers. Contacter le service après vente ou votre revendeur ou s'adresser à un personnel qualifié uniquement.

**OUVERTURES ET ORIFICES :** Les appareils peuvent comporter des ouvertures (aération, fentes, etc...), veuillez ne jamais y introduire d'objets et ne jamais obstruer ses ouvertures. Si un liquide ou un objet pénètre à l'intérieur de l'appareil, débranchez immédiatement l'appareil et faites le contrôler par un personnel qualifié avant de le remettre en service.

## **ISTRUZIONI DI SICUREZZA**

Allo scopo di capire meglio il funzionamento di questa apparecchiatura vi consigliamo di leggere bene tutti i consigli di sicurezza e di funzionamento prima dell'utilizzo. Conservare le istruzioni di sicurezza e di funzionamento al fine di poterle consultare ulteriormente. Seguire tutti i consigli indicati su questo manuale e sull'apparecchiatura.

**ATTENZIONE :** Al fine di prevenire qualsiasi rischio di shock elettrico e d'incendio, non esporre l'apparecchiatura a pioggia, umidità e a sorgenti di eccessivo calore.

**INSTALLAZIONE :** Assicuratevi che vi sia una sufficiente circolazione d'aria per evitare qualsiasi surriscaldamento all'interno dell'apparecchiatura. Non collocare l'apparecchiatura in prossimità o su superfici tessili suscettibili di ostruire il funzionamento della ventilazione. Non installate l'apparecchiatura in prossimità di sorgenti di calore come un radiatore o una fuoruscita d'aria calda, né in un posto esposto direttamente ai raggi del sole, a polvere eccessiva, a vibrazioni o a shock meccanici. Ciò potrebbe provocare un erroneo funzionamento e un incidente.

**ALIMENTAZIONE :** Far funzionare l'apparecchiatura solo con la sorgente d'alimentazione indicata sull'apparecchiatura o sul suo alimentatore. Per le apparecchiature fornite di un'alimentazione principale con cavo di terra, queste devono essere obbligatoriamente collegate su una sorgente fornita di una efficiente messa a terra. In nessun caso questo collegamento potrà essere modificato, sostituito o eliminato.

**CAVO DI ALIMENTAZIONE :** Per le apparecchiature fornite di interruttore generale (Acceso I / Spento O), l'accensione e lo spegnimento dell'apparecchiatura si effettuano attraverso l'interruttore. Per le apparecchiature senza interruttore generale, l'accensione e lo spegnimento si effettuano direttamente inserendo o disinserendo la spina del cavo nella presa murale.

In entrambe i casi applicare i seguenti consigli :

- Disconnettere l'apparecchiatura dalla presa murale se si prevede di non utilizzarla per qualche giorno.
- Per disconnettere il cavo tirare facendo forza sul connettore.
- La presa d'alimentazione deve trovarsi in prossimità dell'apparecchiatura ed essere facilmente accessibile.
- Non far cadere il cavo di alimentazione né appoggiarci sopra degli oggetti pesanti.

Se il cavo di alimentazione è danneggiato, spegnere immediatamente l'apparecchiatura. E' pericoloso far funzionare questa apparecchiatura con un cavo di alimentazione danneggiato, un cavo graffiato può provocare un rischio di incendio o uno shock elettrico. Verificare il cavo di alimentazione spesso. Contattare il vostro rivenditore o il servizio assistenza per una sostituzione.

**CONNESSIONE :** Tutti gli ingressi e le uscite (eccetto l'alimentazione) sono di tipo TBTS definite secondo EN 60950.

**RIPARAZIONI E ASSISTENZA :** L'utilizzatore non deve in nessun caso cercare di riparare l'apparecchiatura, poiché con l'apertura del coperchio metallico o di qualsiasi altro pezzo costituente la scatola metallica, nonché svitare le viti che appaiono esteriormente, poiché ciò può provocare all'utilizzatore un rischio di shock elettrico o altri rischi.

**APERTURE DI VENTILAZIONE :** Le apparecchiature possono comportare delle aperture di ventilazione, si prega di non introdurre mai oggetti o ostruire le sue fessure. Se un liquido o un oggetto penetra all'interno dell'apparecchiatura, disconnetterla e farla controllare da personale qualificato prima di rimetterla in servizio.

**SICHERHEITSHINWEISE:**

Um den Betrieb dieses Geräts zu verstehen, raten wir Ihnen vor der Inbetriebnahme alle Sicherheits- und Betriebsanweisungen genau zu lesen. Diese Sicherheits- und Betriebsanweisungen für einen späteren Gebrauch sicher aufbewahren. Alle in den Unterlagen, an dem Gerät und hier angegebenen Sicherheitsanweisungen einhalten.

**VORSICHT & WARNUNG**

**ACHTUNG:** um jegliches Risiko eines Stromschlags oder Feuers zu vermeiden, das Gerät nicht Regen, Feuchtigkeit oder intensiven Wärmequellen aussetzen.

**EINBAU :** Eine ausreichende Luftzufuhr sicherstellen, um jegliche Überhitzung im Gerät zu vermeiden. Das Gerät nicht auf und in Nähe von Textiloberflächen, die Belüftungsöffnungen verschließen können, aufstellen. Das Gerät nicht in Nähe von Wärmequellen, wie z.B. Heizkörper oder Warmluftkappe, aufstellen und es nicht dem direkten Sonnenlicht, übermäßigem Staub, Vibrationen oder mechanischen Stößen aussetzen. Dies kann zu Betriebsstörungen und Unfällen führen.

**STROMVERSORGUNG :** Das Gerät nur mit der auf dem Gerät oder dem Netzteil angegebenen Netzspannung betreiben. Geräte mit geerdeter Hauptstromversorgung müssen an eine Stromquelle mit effizienter Erdung angeschlossen werden. Diese Erdung darf auf keinen Fall geändert, umgangen oder entfernt werden.

**STROMKABEL :** Für Geräte mit einem Hauptschalter (Ein/Aus) erfolgt die Stromversorgung und unterbrechung mittels dieses Hauptschalters. Geräte ohne Hauptschalter werden durch das Einstecken oder Herausziehen des Steckers in den Wandanschluß ein- oder ausgeschaltet. Für beide Fälle gelten folgende Richtlinien :

- Den Stecker aus dem Wandanschluß herausziehen wenn Sie das Gerät mehrere Tage oder länger nicht benutzen.
- Das Kabel mittels dem Stecker herausziehen. Niemals am Stromkabel selbst ziehen.
- Die Steckdose muß sich in der Nähe des Geräts befinden und leicht zugänglich sein.
- Das Stromkabel nicht fallen lassen und keine schweren Gegenstände auf es stellen.

Wenn das Stromkabel beschädigt ist, das Gerät sofort abschalten. Es ist gefährlich das Gerät mit einem beschädigten Stromkabel zu betreiben; ein abgenutztes Kabel kann zu einem Feuer oder Stromschlag führen. Das Stromkabel regelmäßig untersuchen. Für den Ersatz, wenden Sie sich an Ihren Verkäufer oder Kundendienststelle.

**ANSCHLÜSSE :** Bei allen Ein- und Ausgängen (außer der Stromversorgung) handelt es sich, gemäß EN 60950, um Sicherheits Kleinspannungsanschlüsse.

**REPARATUR UND WARTUNG :** Der Benutzer darf keinesfalls versuchen das Gerät selbst zu reparieren, die Öffnung des Geräts durch Abnahme der Abdeckhaube oder jeglichen anderen Teils des Gehäuses sowie die Entfernung von außen sichtbaren Schrauben zu Stromschlägen oder anderen Gefahren für den Benutzer führen kann. Wenden Sie sich an Ihren Verkäufer, Ihre Kundendienststelle oder an qualifizierte Fachkräfte.

**ÖFFNUNGEN UND MUNDUNGEN :** Die Geräte können über Öffnungen verfügen (Belüftung, Schlitze, usw.). Niemals Gegenstände in die Öffnungen einführen oder die Öffnungen verschließen. Wenn eine Flüssigkeit oder ein Gegenstand in das Gerät gelangt, den Stecker herausziehen und es vor einer neuen Inbetriebnahme von qualifiziertem Fachpersonal überprüfen lassen.

**INSTRUCCIONES DE SEGURIDAD:**

Para comprender mejor el funcionamiento de este aparato, le recomendamos que lea cuidadosamente todas las consignas de seguridad y de funcionamiento del aparato antes de usarlo. Conserve las instrucciones de seguridad y de funcionamiento para que pueda consultarlas posteriormente. Respete todas las consignas indicadas en la documentación, relacionadas con el producto y este documento.

**PRECAUCIONES Y OBSERVACIONES**

**CUIDADO :** Para prevenir cualquier riesgo de choque eléctrico y de incendio, no exponga este aparato a la lluvia, a la humedad ni a fuentes de calor intensas.

**INSTALACIÓN :** Cerciórese de que haya una circulación de aire suficiente para evitar cualquier sobrecalentamiento al interior del aparato. No coloque el aparato cerca ni sobre una superficie textil que pudiera obstruir los orificios de ventilación. No instale el aparato cerca de fuentes de calor como radiador o boca de aire caliente, ni en un lugar expuesto a los rayos solares directos o al polvo excesivo, a las vibraciones o a los choques mecánicos. Esto podría provocar su mal funcionamiento o un accidente.

**ALIMENTACIÓN :** Ponga a funcionar el aparato únicamente con la fuente de alimentación que se indica en el aparato o en su bloque de alimentación. Los aparatos equipados con una alimentación principal con hilo de tierra deben estar conectados obligatoriamente a una fuente equipada con una puesta a tierra eficaz. Por ningún motivo este enlace de tierra deberá ser modificado, cambiado o suprimido.

**CABLE DE ALIMENTACIÓN :** Para los aparatos equipados con un interruptor general (Marcha I / Paro O), la puesta bajo tensión y la puesta fuera de tensión se hace accionando este interruptor general.. En los aparatos que no tienen interruptor general, la puesta bajo tensión y la puesta fuera de tensión se hace directamente conectando y desconectando el enchufe mural.

En ambos casos, se deberá respetar las siguientes consignas:

- Desconectar el aparato del enchufe mural si no piensa utilizarlo durante varios días.
- Para desconectar el cable, tire de la clavija. No tire nunca del cable propiamente dicho.
- El enchufe de alimentación debe estar cerca del aparato y ser de fácil acceso.
- No deje caer el cable de alimentación ni coloque objetos pesados encima de él.

Si el cable de alimentación sufre algún daño, ponga el aparato inmediatamente fuera de tensión. Es peligroso hacer funcionar este aparato con un cable averiado, ya que un cable dañado puede provocar un incendio o un choque eléctrico. Verifique el estado del cable de alimentación de vez en cuando. Póngase en contacto con su distribuidor o con el servicio de posventa si necesita cambiarlo.

**CONEXIONES :** Todas las entradas y salidas (excepto la entrada del sector) son de tipo TBTS (Muy Baja Tensión de Seguridad) definidas según EN 60950

**REPARACIÓN Y MANTENIMIENTO :** Por ningún motivo, el usuario deberá tratar de efectuar operaciones de reparación, ya que si abre los aparatos retirando el capó o cualquier otra pieza que forma parte de las cajas o si destornilla los tornillos aparentes exteriores, existe el riesgo de producirse una explosión, choques eléctricos o cualquier otro incidente. Contacte el servicio de posventa, a su distribuidor o diríjase con personal cualificado únicamente.

**ABERTURAS Y ORIFICIOS :** Los aparatos pueden contener aberturas (aireación, ranuras, etc.). No introduzca allí ningún objeto ni obstruya nunca estas aberturas. Si un líquido o un objeto penetra al interior del aparato, desconéctelo y hágalo revisar por personal cualificado antes de ponerlo nuevamente en servicio.

# GRAPHIC SWITCHER II™ (GSW2811R)

## Chapter 1 : INTRODUCTION

### 1-1. SUPPLIED EQUIPMENT

- 1 GRAPHIC SWITCHER II™ (GSW2811R).
- 1 AC power supply cord.
- 1 user’s manual.
- 1 remote control software (3.5" disk).

**Supplied equipment with the OPT-GSW2-VO option:**

- 1 video output cable (DB9 M to 4BNC + mini DIN 4).

### 1-2. GENERAL INFORMATION

The seamless GRAPHIC SWITCHER II™ inserts (PIP), cuts, fades, wipes and instantaneously mixes (no glitch) between 16 high-resolution and TV/Video sources which can range (Auto Sync and Auto Scan) from 15 kHz up to 130 kHz (up to 1600 x 1280), with no synchronization "dropouts".

The GRAPHIC SWITCHER II™ Up or Down scales each input to one user-programmable output format, matching the native resolution of any projector (LCD, DLP or CRT), plasma display, video wall or multisync. monitor. All input and output parameters and formats can be stored and saved as NON-volatile memory. In addition, several sequences with users’ effects can be run automatically. An RS-232 Remote Control input is provided.

**The GRAPHIC SWITCHER II™’s outputs are:**

- 1 MAIN output “PROGRAM” (BNC + HD15).
- 1 PREVIEW output “PRESET” for visualization and adjustment before the switch.
- 4 TALLY outputs (that can be selected from any of the 16 inputs to indicate who is “ON AIR”).
- TV/VIDEO output (option).

The output format can be selected in HDTV, D-ILA, SXGA, XGA<sub>2</sub>, SVGA, or VGA and remains constant no matter which input is selected. This allows for a "one time" adjustment of your display device.

The GRAPHIC SWITCHER II™ comes with a “natural color” Comb Filtering decoder with a robust sync. detection, an enhanced 3D Auto Adaptive Motion Compensation video scaling process and a 3/2 pull down Film to video correction (NTSC). This device takes the term “user friendly” to a new level. PIP (Picture in Picture), seamless fading and effects combined with direct access auto-recognition inputs, makes live High End presentations better and easier than before. It can be easily updated by software for new features.

For Multi-screen applications, 2 or 3 GRAPHIC SWITCHER II™’s can be “Stacked” together and controlled by only one Remote Control Unit (RCU2811). Also available is an optional "Show Manager" software to control 1 to 16 devices with fully automated different sequences & input selection.

### 1-3. GRAPHIC SWITCHER II™ REFERENCES

REFERENCES	DESIGNATIONS
GSW2811R	GRAPHIC SWITCHER II™ (without option)
GSW2811R-D1	GRAPHIC SWITCHER II™ (with optional SDI input)
OPT-GSW2-VO	Optional video outputs (Composite video + S.VIDEO + YUV)
ADD-ON-1	Optional upgrade for "Edge blending" application.
ADD-ON-2	Optional upgrade for PIP, POP & TITLE switching.

### 1-4. GRAPHIC SWITCHER II™ OPTIONAL ACCESSORIES

REFERENCES	DESIGNATIONS
RCU2811	REMOTE CONTROL UNIT (allows to control up to 3 GSW2811R/GSE2811R)
SWM2811	SHOW MANAGER™ control software (allows to control up to 16 GSW2811R/GSE2811R)
KSW2811	KIT DOUBLER CONTROL FOR 3 GSW2811R/GSE2811R.

## **Chapter 2 : INSTALLATION**

**IMPORTANT:** Please read all of the safety instructions (pages 2 to 4) before starting.

- Table top mounting: The GRAPHIC SWITCHER II™ can be used directly on a table: the unit is equipped with 4 plastic feet.
- Rack mounting: The GRAPHIC SWITCHER II™ is compatible with a 19" enclosure. Please follow the instructions below to install the GRAPHIC SWITCHER II™ in a 19" rack.

① Place the GRAPHIC SWITCHER II™ in your rack.

**NOTE:** Your rack must be equipped with some braces.

② Attach the GRAPHIC SWITCHER II™ to the rack by using 4 screws in the front panel holes (screws are not included).

③ Connect all of the cables of the GRAPHIC SWITCHER II™ and attach them to the rack with some tie wraps.

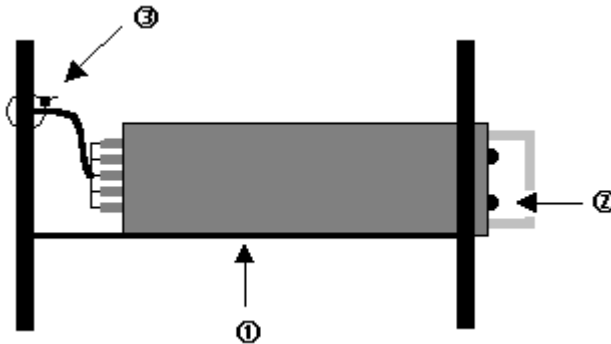

- IMPORTANT:**
- The openings in the front and in the rear panels are for cooling. Do not cover these openings.
  - Be sure that no weight in excess of 2 kg (4.4 Lbs.) is added onto the GRAPHIC SWITCHER II™.
  - The maximum ambient operating temperature must not exceed 40 °C (104 °F).
  - The rack and all mounted equipment in it must be reliably grounded to national and local electrical codes.

**Chapter 3 : TECHNICAL DESCRIPTION**

**3-1. FRONT PANEL**



**INPUT SELECT (PROGRAM & PREVIEW)**

- 1 to 8 :** 8 RGB/YUV input selection keys.
- 9 to 16 :** 8 Composite Video input selection keys.
- S1 to S4 :** 4 S.VIDEO (Y/C) input selection keys.
- SDI :** Optional SDI input selection key.
- BLACK :** BLACK screen selection key.

**TRANSITION - EFFECTS**

- TAKE :** Allows to switch the pre-selected input (blinking key) on the MAIN output with the pre-selected EFFECT (EFFECT KEYS).
- 1, 2, 3, 4 :** Four EFFECT keys. Each of those keys can store one of the effects available in the LCD effect menu.

**FREEZE MAIN**

Allows to FREEZE the MAIN output image (active when the key is ON).

**FREEZE PREVIEW**

Allows to FREEZE the PREVIEW output image (active when the key is ON).

**ADJUST**

- RECALL / STORE :** STORE (a long push, LED = ON): allows to store for each input, the image adjustments (position, size).  
RECALL (a short push on the button): allows to recall the stored image settings for the selected input.

**NOTE:** The GRAPHIC SWITCHER II™ has 40 NON-volatile image setting memories.

**POS / SIZE :** Position or Size mode selection. (Acts on **H** & **V** buttons).

**H :** Horizontal image control (position or size).

**V :** Vertical image control (position or size).

**MAIN & PREVIEW :** Output selection for the adjust functions.

**NOTE:** The adjust functions are active on the output indicated by the turned ON LED's (MAIN and/or PREVIEW).

**LCD WINDOWS**

**CONTROL ◀ ▶** Allows to select items in the LCD menu.

**EXIT / MENU :** Allows to exit from a LCD menu.

**ENTER :** Allows to validate the selected item.

**STEP**

(SEQUENCE)

Allows to directly step through a programmed switching sequence.

3-2. REAR PANEL

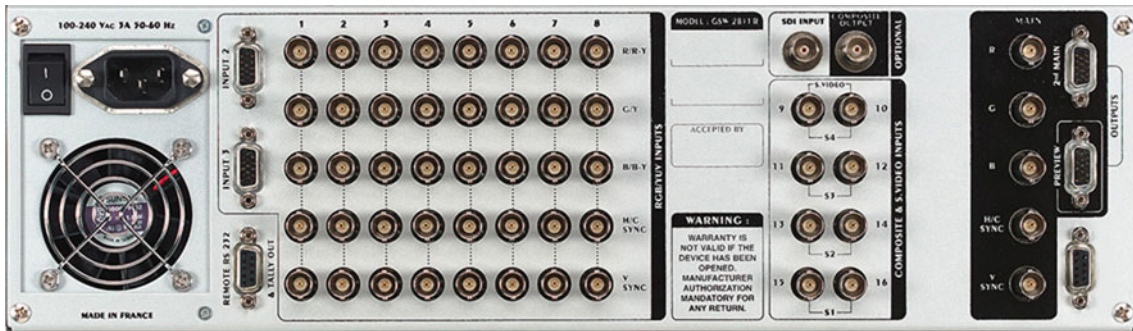

**POWER CONNECTOR:** Standard IEC input connector (100-240 VAC, 50-60Hz automatic).

**O / I :** Power switch (O = OFF, I = ON)

**RGB / YUV INPUTS**

**1 to 8 :**

8 x RGB/YUV inputs on 3, 4, or 5 BNC connectors. The RGB/YUV inputs can accept both COMPUTER sources (RGBHV, RGBS, and RGsB (SOG) signals), standard TV/VIDEO sources (YUV, RGBS (TTL), RGsB (SOG), and RGBS (analog) signals), and HDTV SOURCES (720p & 1080i with bi-level sync only).

- RGB HV (Separate H & V Sync.) : on 5 BNC connectors.
- RGB S (Composite Sync.) : on 4 BNC connectors (R, G, B, C SYNC).
- RGsB (SOG) : on 3 BNC connectors (R, G, B).
- YUV (COMPONENT) : on 3 BNC connectors (R-Y, Y, B-Y).
- 720p & 1080i with bi-level sync : on 5 BNC connectors (RGBHV).

**INPUT 2 :** 2<sup>nd</sup> connector (HD 15 F) of the RGB/YUV INPUT 2.

**INPUT 3 :** 2<sup>nd</sup> connector (HD 15 F) of the RGB/YUV INPUT 3.

**NOTE:** For the INPUT #2 and #3, never connect simultaneously sources on the HD15 and on the BNC connectors.

**REMOTE RS-232 & TALLY OUT**

**RS-232 :** Standard remote control RS-232 on DB9 F connector.

**TALLY OUT :** 4 tally outputs on DB9 F connector.

**NOTE:** This connector is also used for updating the GRAPHIC SWITCHER II™. (See Chapter 8 : UPDATING THE GRAPHIC SWITCHER II™).

**OPTIONAL**

**SDI INPUT :** Optional SDI input on BNC connector.

**COMPOSITE OUTPUT :** Optional composite output on BNC connector.

**COMPOSITE & S.VIDEO INPUTS**

**9 to 16 :** 8 composite video inputs on BNC connectors.

**S1 to S4 :** 4 S.VIDEO (Y/C) inputs on 2 x BNC connectors.

**OUTPUTS**

**MAIN :** MAIN output for the MAIN display device (video projector, PLASMA, data monitor) on 3, 4, or 5 BNC connectors.

**2<sup>nd</sup> MAIN :** Additional MAIN output on HD15 F connector.

**PREVIEW :** PREVIEW output for the PREVIEW MONITOR, on HD 15 F connector.

**OPTIONAL VIDEO OUTPUT**

Optional video output (YUV or S.VIDEO) on DB9 F connector.





## Chapter 4 : STARTING

### 4-1. CONNECTIONS

- ① Turn OFF all of your equipment before connecting.
- ② Connect your computers (PC, MAC, workstation), your component and RGBS video sources to the inputs (1 to 8) of the GSW2811R.
- ③ Connect your COMPOSITE sources to the inputs (9 to 16) and/or your S.VIDEO sources to the inputs (S1 to S4).
- ④ Connect your MAIN display device (data projector, plasma screen...) to the "MAIN" output (BNC (x5) connectors).
- ⑤ Connect your control monitors to the PREVIEW output and to the 2<sup>nd</sup> MAIN output (HD15 connectors).
- ⑥ Connect the AC power supply cord to the GRAPHIC SWITCHER II™ and to a power outlet.
- ⑦ Turn ON the projector, the local monitors, the GRAPHIC SWITCHER II™ (rear panel switch) and then all of your input sources.

**NOTE:** If the output image pixelize, switch OFF and ON the GRAPHIC SWITCHER II™.

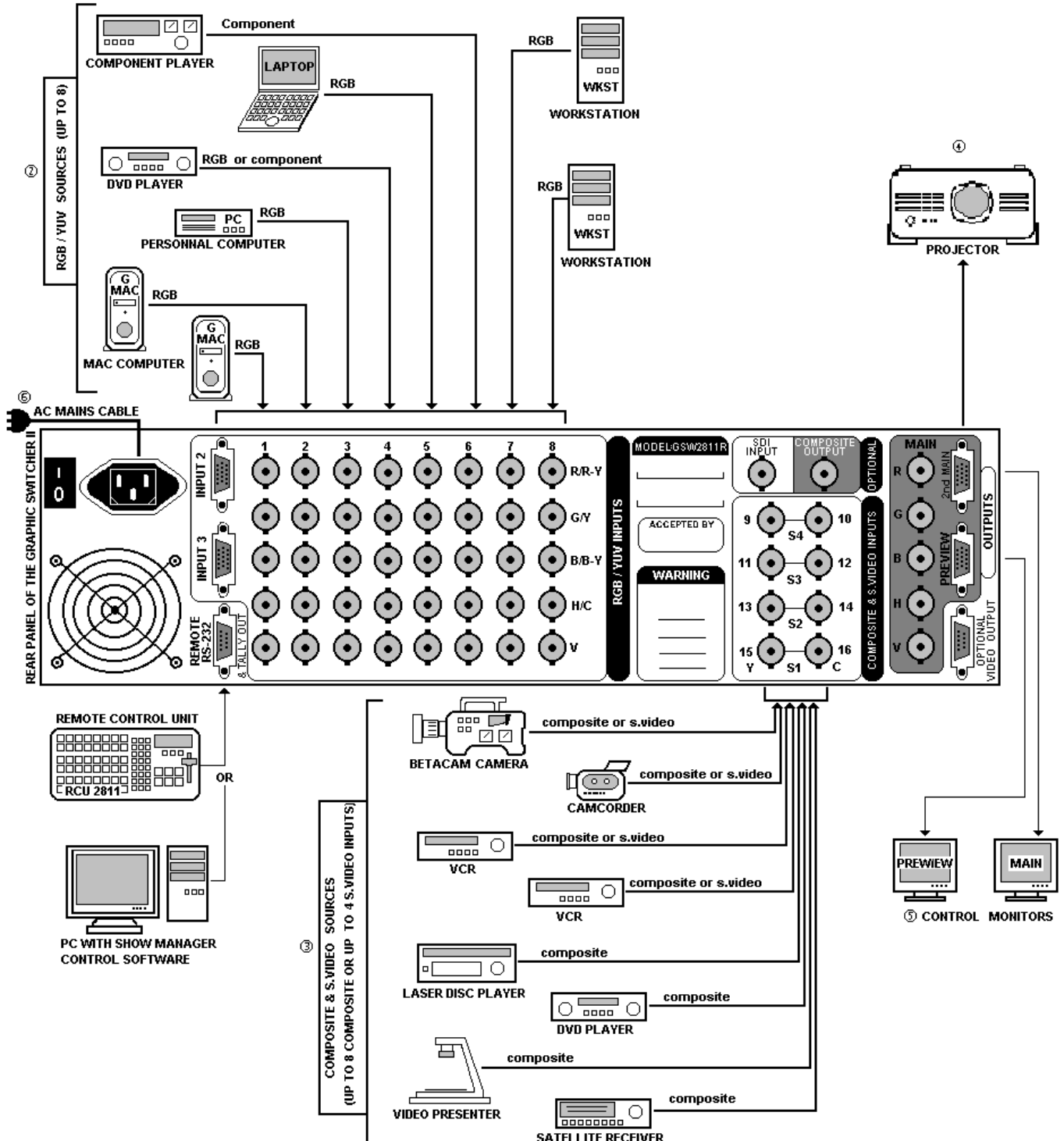

4-2. RGB/YUV INPUTS (1 to 8)

The RGB/YUV INPUTS can accept both COMPUTER sources (RGBHV, RGBS, and RGsB (SOG) signals), standard TV/VIDEO sources (YUV(Component), RGBS (TTL), RGsB (SOG), and RGBS (analog) signals), and HDTV sources (720p & 1080i with bi-level sync only).

① COMPUTER SOURCES:

Connect your COMPUTERS (PC, MAC, WORKSTATION) with BNC (x5) cables to the RGBHV (#1 to #8) inputs.

**NOTE:** • For RGBS signals connect the Sync cable to the H/C BNC connector.

- The Input #2 and #3, are equipped with an additional HD15 connector. You can also connect your computer source either on the BNC connectors **or** either on the HD15 connector.

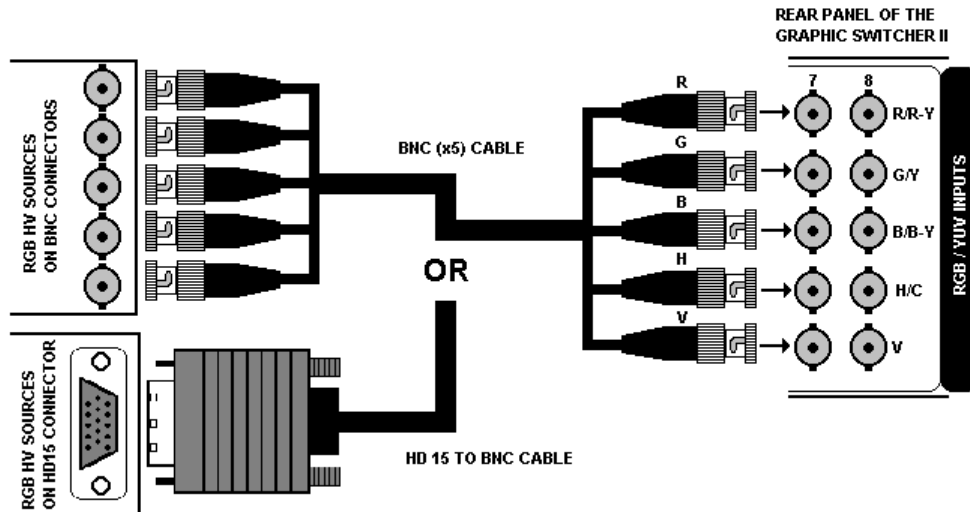

② TV/VIDEO SOURCES:

• COMPONENT VIDEO SIGNAL :

The Component Video signal, also called YUV (Y, R-Y, B-Y) or BETACAM™ is widely used in broadcasting and is available on high-quality DVD players. The COMPONENT signal is transmitted with 3 coaxial cables, and also has a better quality picture than COMPOSITE and S.VIDEO signals. The COMPONENT connectors are usually RCA (x3), or BNC (x3).

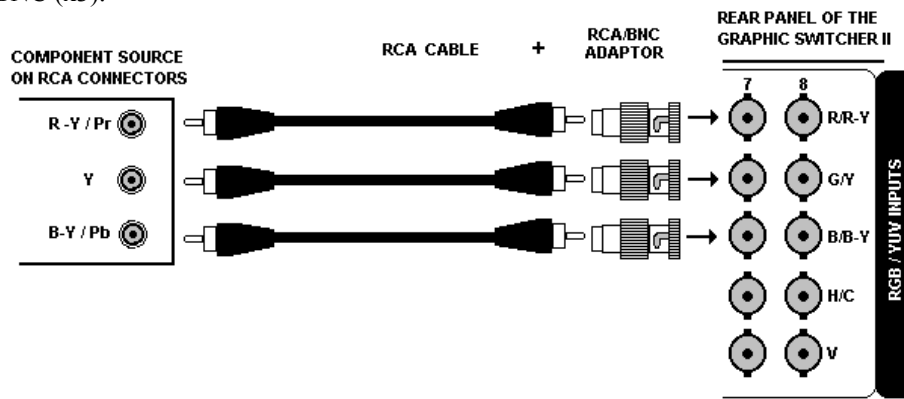

• RGBS VIDEO SIGNAL:

This signal is widely used in broadcasting and is available on European DVD player and Satellite receivers. The RGB.S signal is transmitted with 4 coaxial cables, and also has a better picture quality than COMPOSITE and S.VIDEO signals. The RGB.S connectors are usually BNC connectors for Broadcasting equipment, and SCART connector for DVD players and Satellite Receivers. Connect the RGBS VIDEO signal with BNC cables to the R, G, B, H/C BNC connectors of the #1 to #8 inputs of the GRAPHIC SWITCHER II™.

③ HDTV SOURCES:

• **720p & 1080i:** The GRAPHIC SWITCHER II™ accepts the 720p & 1080i HDTV formats with bi-level sync only (RGBHV). Connect your HDTV signal as a Computer signal. For signals with tri-level sync you may required an interface (i.e.: TV-HDTV INTERFACE, reference: HDI100).



4-3. COMPOSITE INPUTS (9 to 16) & S.VIDEO INPUTS (S1 to S4):

The **Composite Video** signal, usually called COMPOSITE or VIDEO, is available on most video equipment (VCR, DVD, CAMCORDER...), but is also the lowest in picture quality. The video standard of this signal can be NTSC, PAL or SECAM. The signal is transmitted on a single coaxial cable, and is connected to the video equipment with an RCA or a BNC connector.

The **S.VIDEO** signal, also called Y/C, HI-8™, or S.VHS™, is available on DVD players and high quality VCRs (S.VHS). The S.VIDEO signal in which the Luminance (Y) and Chrominance (C) informations are separately transmitted (2 wires) gives a higher quality picture than the Composite video signal. The S.VIDEO connector is usually a 4 pin Mini-DIN connector also called Oshiden™ connector. It can also sometimes be on 2 BNC connectors.

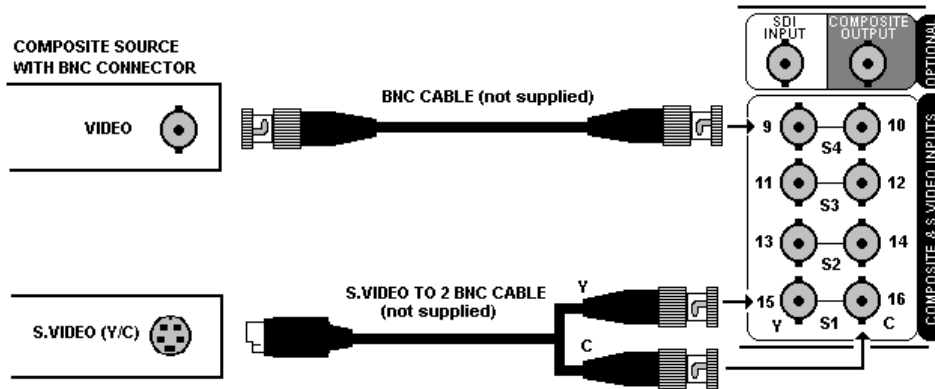

4-4. MAIN AND PREVIEW OUTPUTS

The GRAPHIC SWITCHER II™ is equipped with 1 MAIN OUTPUT on BNC (x5) connectors for the DISPLAY DEVICE, and two monitoring outputs on HD 15 connectors.

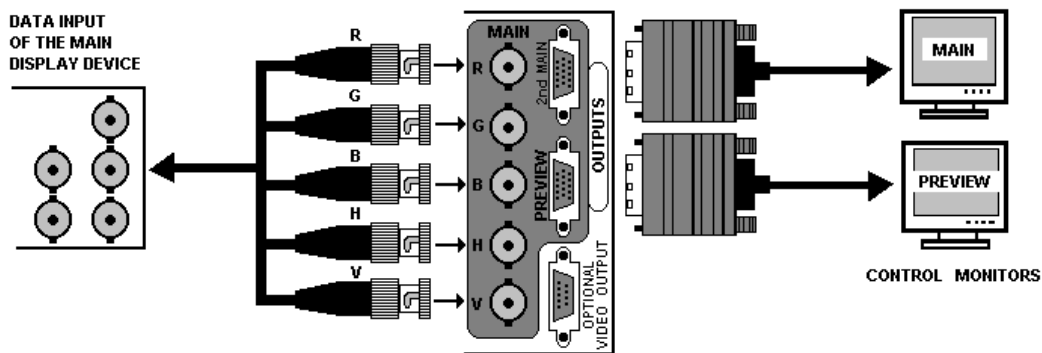

4-5. OPTIONAL VIDEO OUTPUT (OPT-GSW2-VO option)

The GRAPHIC SWITCHER II™ equipped with this option provides simultaneously 3 video signals (composite video, S.VIDEO and YUV) in output. These 3 video outputs display the same image as the MAIN output. Therefore you can record your presentation onto one or many video recorders of your choice.

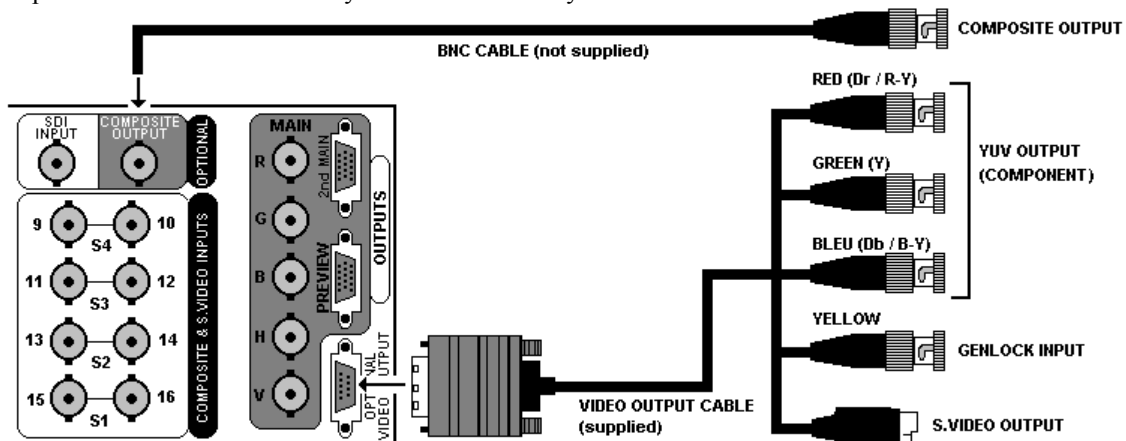

**Chapter 5 : OPERATING MODE**

**5-1. SETTINGS**

- ① We recommend resetting the GRAPHIC SWITCHER II™ to all of its **default values**, with the LCD screen (**control menu > default value > yes**) before proceeding. Then switch OFF and ON the device.
  - ② Select the type of signal connected to the RGB/YUV inputs (**input menu > RGB/YUV inputs >...**).
  - ③ Select the **Output sync.** type which correspond to your display device (**outputs menu > output sync >...**).
  - ④ Select the **Output rate** mode (**outputs menu > output rate >...**). Please see the Output rate mode table below.
  - ⑤ Select an **Output format** (**outputs menu > output format >...**).
- NOTE:** For fixed pixels display device (DMD, LCD, PLASMA...), always select the output format corresponding to the native resolution of your display device. Thus, the display device will not have to scale the image and the result will be better.
- ⑥ Select the **Type of screen** corresponding to your wall mounted projection screen shape (**outputs menu > type of screen > 4/3 or 16/9**).
  - ⑦ Select the COMPOSITE & S.VIDEO mode corresponding to your configuration (**input menu > CV/SV mode >...**).
  - ⑧ Disable the unused input KEYS with the LCD screen (**input menu > used inputs >...**).
    - Light OFF = disabled input.
    - Light ON = selected input.
    - Low light = not selected input.
    - Blinking light = pre-selected input.

**OUTPUT RATE MODE TABLE**

MODES	Output rate = "input #" rate	Output rate = internal rate
APPLICATIONS	Movie and motion pictures display.	Video presentation (static pictures).
OUTPUT RATE	Locked on the Frame Rate of the video input selected in the "Output rate" menu (menu # 2-2) (50 Hz if PAL or SECAM and 59.94 Hz if NTSC)	Generated by the GRAPHIC SWITCHER II™ (60 Hz or 75 Hz)
OUTPUT FORMAT.	<ul style="list-style-type: none"> <li>• 640 x 480 L</li> <li>• 800 x 600 L</li> <li>• 1024 x 768 L</li> <li>• 1280 x 1024 L</li> <li>• 1365 x 1024 L</li> <li>• 1365 x 768 L</li> <li>• HDTV 480p</li> <li>• HDTV 720p</li> </ul>	<ul style="list-style-type: none"> <li>• VGA 60 Hz</li> <li>• SVGA 60 Hz</li> <li>• XGA 60 Hz</li> <li>• SXGA 60 Hz</li> <li>• D-ILA 4/3</li> <li>• D-ILA 16/9</li> <li>• HDTV 480p</li> <li>• HDTV 720p</li> <li>• VGA 75 Hz</li> <li>• SVGA 75 Hz</li> <li>• XGA 75 Hz</li> </ul>

**5-2. DISPLAY DEVICES ADJUSTMENTS**

- ① Set the MAIN test pattern on the "ON" position (**outputs menu > test pattern > main > on**). Four corner shapes appear on the MAIN displays.
- ② Adjust directly the display device itself, using its H and V size and position control parameter to fill the four corner shapes in the full screen.

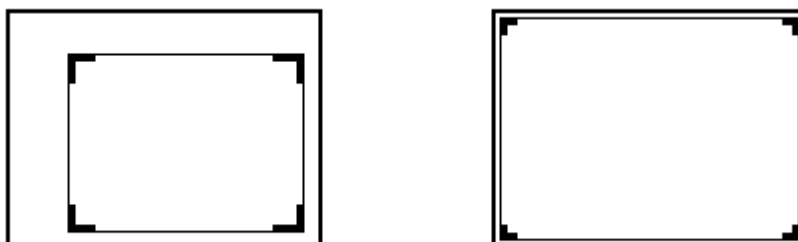

- ③ Renew the same process to adjust your PREVIEW display device.
- NOTE:** Now the display devices are identically adjusted, you can also make the image adjustments on the display device of your choice. When you are in a live display, you can make corrections on the PREVIEW monitor only, without disturbing the MAIN display device.

5-3. IMAGE ADJUSTMENTS

For each input source connected to the GRAPHIC SWITCHER II™, make the following adjustments:

- ① Select the source you want to adjust.
  - NOTE:** To adjust your source on your PREVIEW monitor : you just have to press on the corresponding INPUT SELECT key. The key is blinking and the source is displayed on the PREVIEW monitor.
  - NOTE:** To adjust your source on your MAIN display device : press on the corresponding key (the key is blinking) and press TAKE (the key is ON and the source is displayed on the MAIN display device).
  - NOTE:** If the Pattern is well adjusted on both PREVIEW and MAIN , then the input adjustment can be made on the PREVIEW or MAIN as well.
- ② Select the aspect ratio (4/3, letterbox...) of your source (**image menu > aspect ratio >...**).
- ③ Adjust the vertical and horizontal position (with the front panel "H & V" adjust buttons). The adjustments are visible on the selected output and their values are displayed in the LCD screen.
  - NOTE:** The MAIN and PREVIEW LED'S indicate on which output the adjustment will be performed. To change the output, presses on the MAIN/PREVIEW button.
  - NOTE:** To adjust the SIZE, presses the POS/SIZE button and adjust with the "H & V" adjust buttons. The selected mode (POS or SIZE) is displayed on the LCD screen.

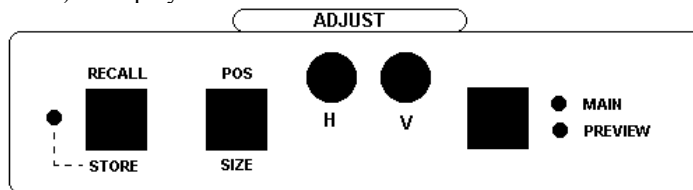

- ④ Press on the STORE button for 2 seconds until the LED flashes once to memorize the position & size adjustments.
  - NOTE:** The GRAPHIC SWITCHER II™ is provided with 40 NON-volatile image memories. Each of these memories contains the input channel number, the input and output format parameters and all of the image adjustments. When the 40 memories are used, each new memorization erases the oldest memory.
- ⑤ If needed, make the others adjustments, available in the LCD **image menu** (color, brightness, image process...). Validate each adjustment with **ENTER**.
  - NOTE:** To erase the image adjustments, use the **Preset** function (**image menu > preset**).

5-4. OPTIONAL VIDEO OUTPUT ADJUSTMENT

- ① Select the video "output rate" (**outputs menu > video output > output rate >...**).
- ② Select the output standard (**outputs menu > video output > video standard > NTSC or PAL**).
- ③ Select the zoom mode (**outputs menu > video output > U/Over scan > underscan or overscan**).
- ④ Select a level of anti-flicker (**outputs menu > video output > flicker adj. >...**).

5-5. SWITCHING OPERATION

- ① Pre-select an input on the input select bus (KEY blinking).
- ② Select a TRANSITION effect on the 1 to 4 EFFECTS keys.
  - NOTE:** The effect stored in the selected EFFECT key is displayed on the LCD screen.
- ③ Press on TAKE. The pre-selected input is displayed on the MAIN output with the selected effect transition.
  - NOTE:** According to the selected effect the TAKE key may turn ON or blink during the transition. When the TAKE key is turned ON you should wait for the end of the transition before doing another selection. When the TAKE key is blinking, then you should press the TAKE key to stop the transition.

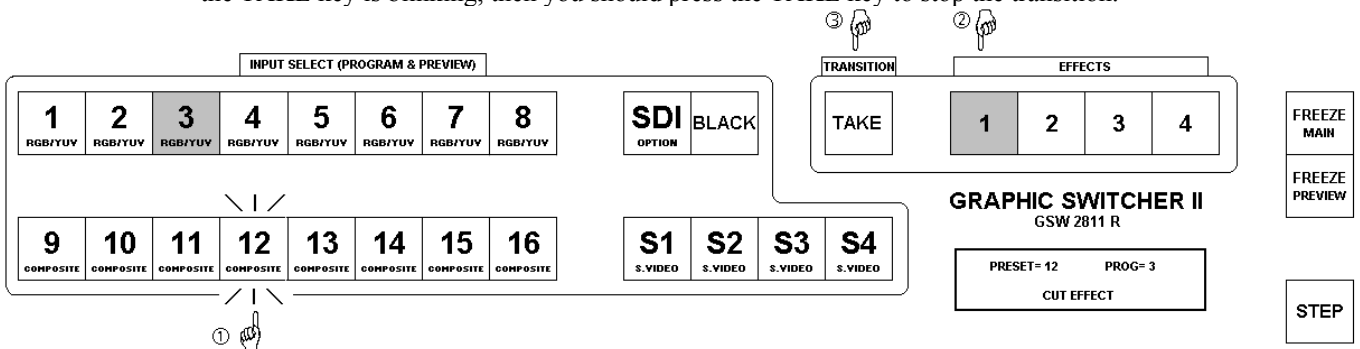

5-6. EXAMPLES OF TRANSITIONS & EFFECTS

① WIPE TRANSITION:

- Assign a WIPE to one of the EFFECTS keys: Press one EFFECTS key, select a WIPE (for example: **hor wipe > left to right**) then select the duration.
- Press the TAKE key to activate the transition: the PREVIEW image appears onto the MAIN display with a wipe transition.

**Example:**

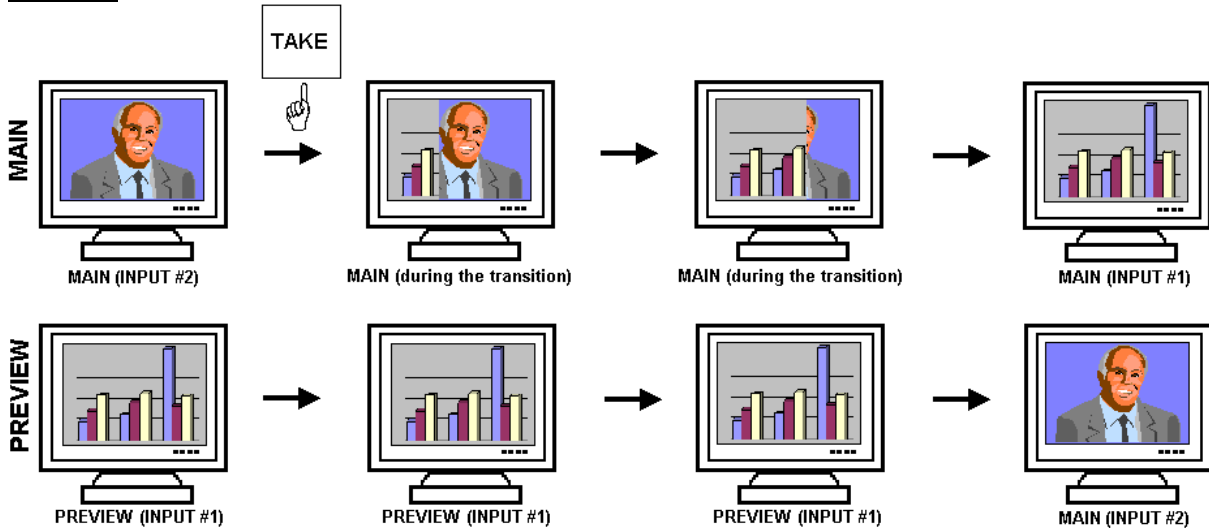

② TITLE EFFECT (OR SHADOW TITLE):

The TITLE effect allows to display a text onto the MAIN image. For a better readability you also can display a shadow bar onto your text.

- Create the text to displayed with the computer connected to the GSW2811R thanks to a drawing software like Power Point (text in white onto a black background).
- Display on the MAIN output the source to titling (INPUT #2 in the example below), then pre-select the source used for create the text: the image appears on the PREVIEW output (INPUT #1 in the example below).
- Assign the TITLE effect to one of the EFFECTS keys: Press one EFFECTS key, select **title** or **shadow title**, then select the duration.
- Press the TAKE key to activate the effect (ACTION 1): the text is now displayed onto the image of the MAIN output.

**NOTE:** With the ADD-ON-2 upgrade, you can change the background image (PREVIEW image) by selecting another input (ACTION 2): the transition operates with a fading to black. To remove the TITLE effect, press the TAKE key (ACTION 3).

**Example:**

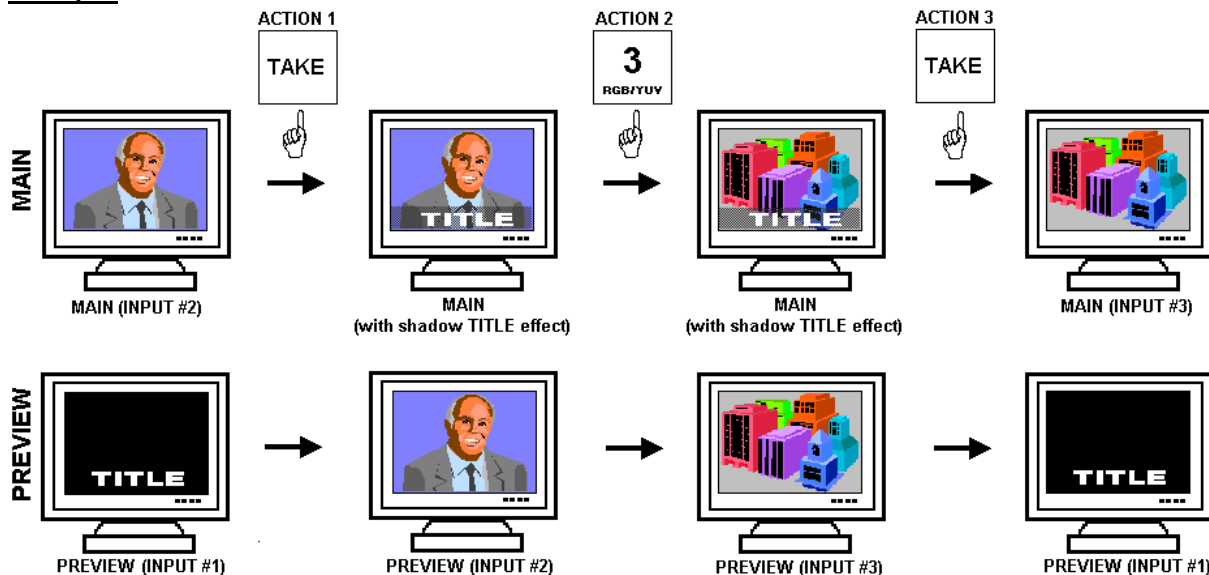

5-6. EXAMPLES OF TRANSITIONS & EFFECTS (continued)

③ PIP EFFECT:

The PIP effect allows to insert an image into another one.

- Assign the PIP effect to one of the EFFECTS keys: Press one EFFECTS key, select **PIP**, then make all the needed adjustments (duration, size, position...).
- Press the TAKE key to activate the effect (ACTION 1 in the example below): the PREVIEW image is now inserted into the MAIN image.

**NOTE:** With the ADD-ON-2 upgrade, you can change the image in the PIP (PREVIEW image) by selecting another input (ACTION 2): the transition operates with a fading to black. To remove the PIP effect, press the TAKE key (ACTION 3).

**Example:**

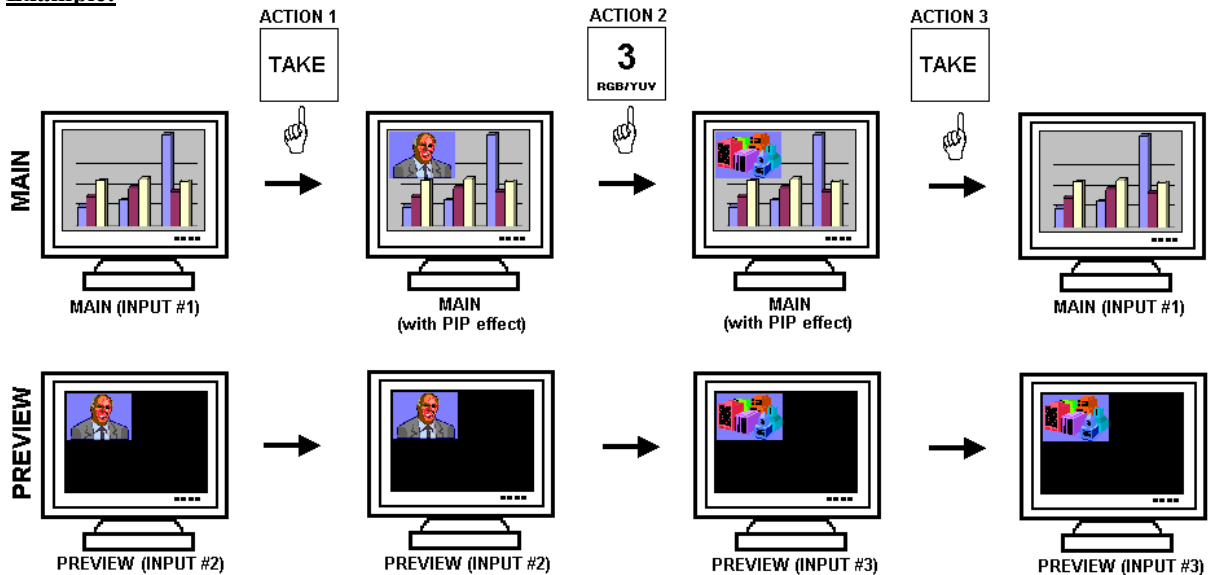

④ POP EFFECT (available with the ADD-ON-2 upgrade only):

The POP effect allows to change the background image when an image is inserted into another one.

- Assign the POP effect to one of the EFFECTS keys: Press one EFFECTS key, select **POP**, then make all the needed adjustments (size, position...).
- Press the TAKE key to activate the effect (ACTION 1 in the example below): the PREVIEW image is now inserted into the MAIN. To change the background image, press directly on the needed input selection key (ACTION 2): the transition operates with a fading to black. To remove the POP effect, press the TAKE key (ACTION 3).

**Example:**

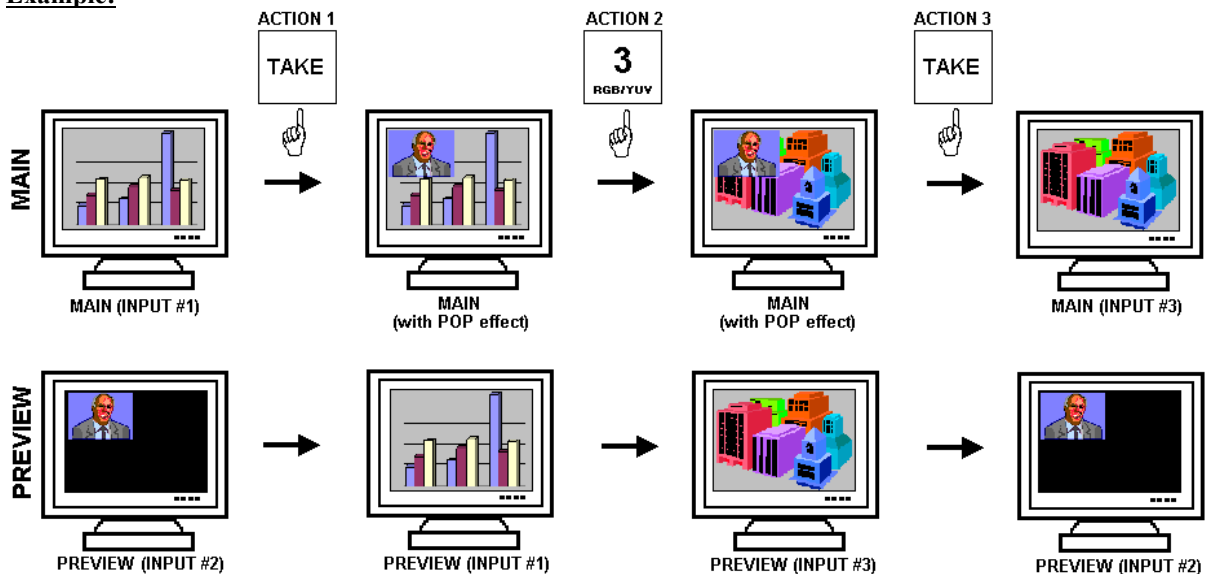

**NOTE:** The POP effect can not be use as extended effect in multi-screen application of the ADD-ON-1 upgrade.

## Chapter 6 : LCD SCREEN DESCRIPTION

### 6-1. INTRODUCTION

The LCD screen is composed of 2 modes: the STATUS MODE and the CONTROL MODE.

- The STATUS MODE indicates the input and the output status of the GRAPHIC SWITCHER II™.
- The CONTROL MODE allows selecting and adjusting the parameters of the GRAPHIC SWITCHER II™.

### 6-2. LCD CONTROL BUTTONS

The LCD screen is controlled by 3 buttons :

◀ ▶ **CONTROL** knob: To scroll thru the different menus.

**EXIT MENU** button:

- From the STATUS MODE, press on this button to display the CONTROL MODE.
- From the CONTROL MODE, press on this button to:
  - return to the previous menu,
  - return to the STATUS MODE (press several times),
  - return without safeguarding the item.

**ENTER** button :

- From the STATUS MODE, press on this button to return to the previous consulted menu.
- From the CONTROL MODE, press on this button to confirm a selected item.

**NOTE:** When entering in the CONTROL MODE, the LCD window will automatically display the STATUS MODE after 60 seconds of inactivity of the front panel buttons.

### 6-3. STATUS MODE

When switching the GRAPHIC SWITCHER II™ ON, the LCD screen displays the product's name and status as follows:

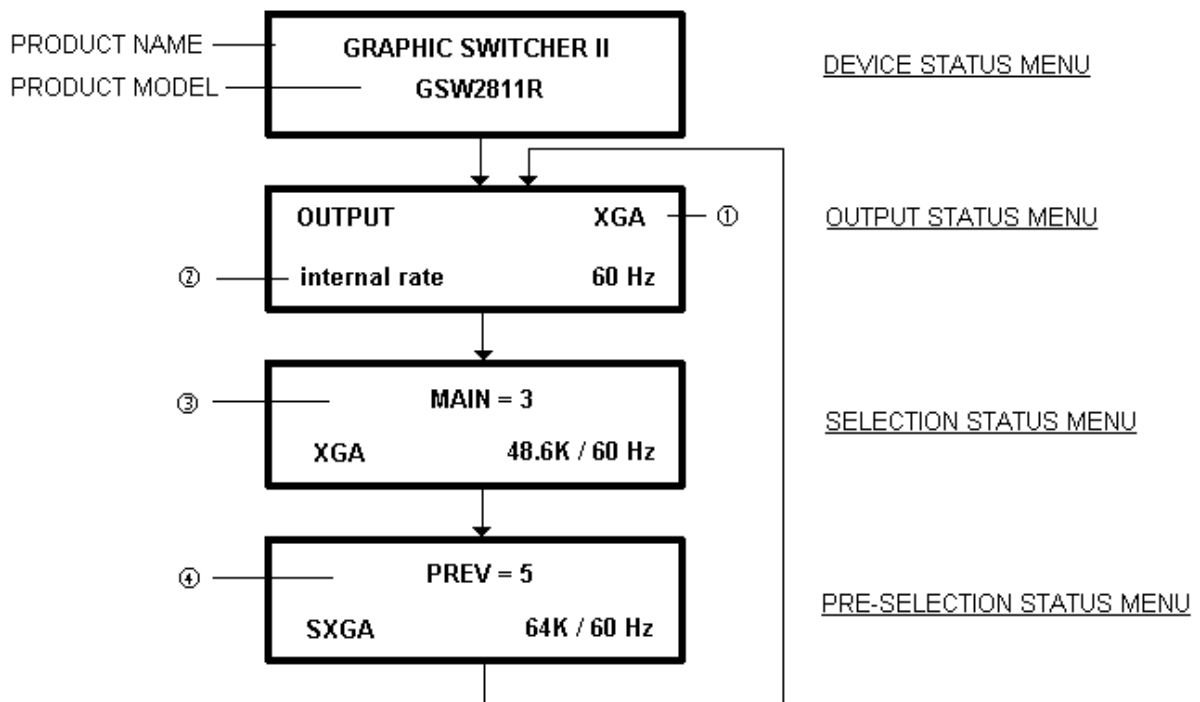

- ① OUTPUT FORMAT
- ② OUTPUT RATE
  - [internal rate] or [input # rate].
  - [60Hz] = output frame frequency.
- ③ SELECTED INPUT
  - [MAIN = 3] = number of the selected input.
  - [XGA] = input format.
  - [48.6K/60Hz] = line frequency / frame frequency.
- ④ PRE-SELECTED INPUT
  - [PREV = 5] = number of the pre selected input.



6-4. CONTROL MODE

The menus of the CONTROL MODE are configured as follow :

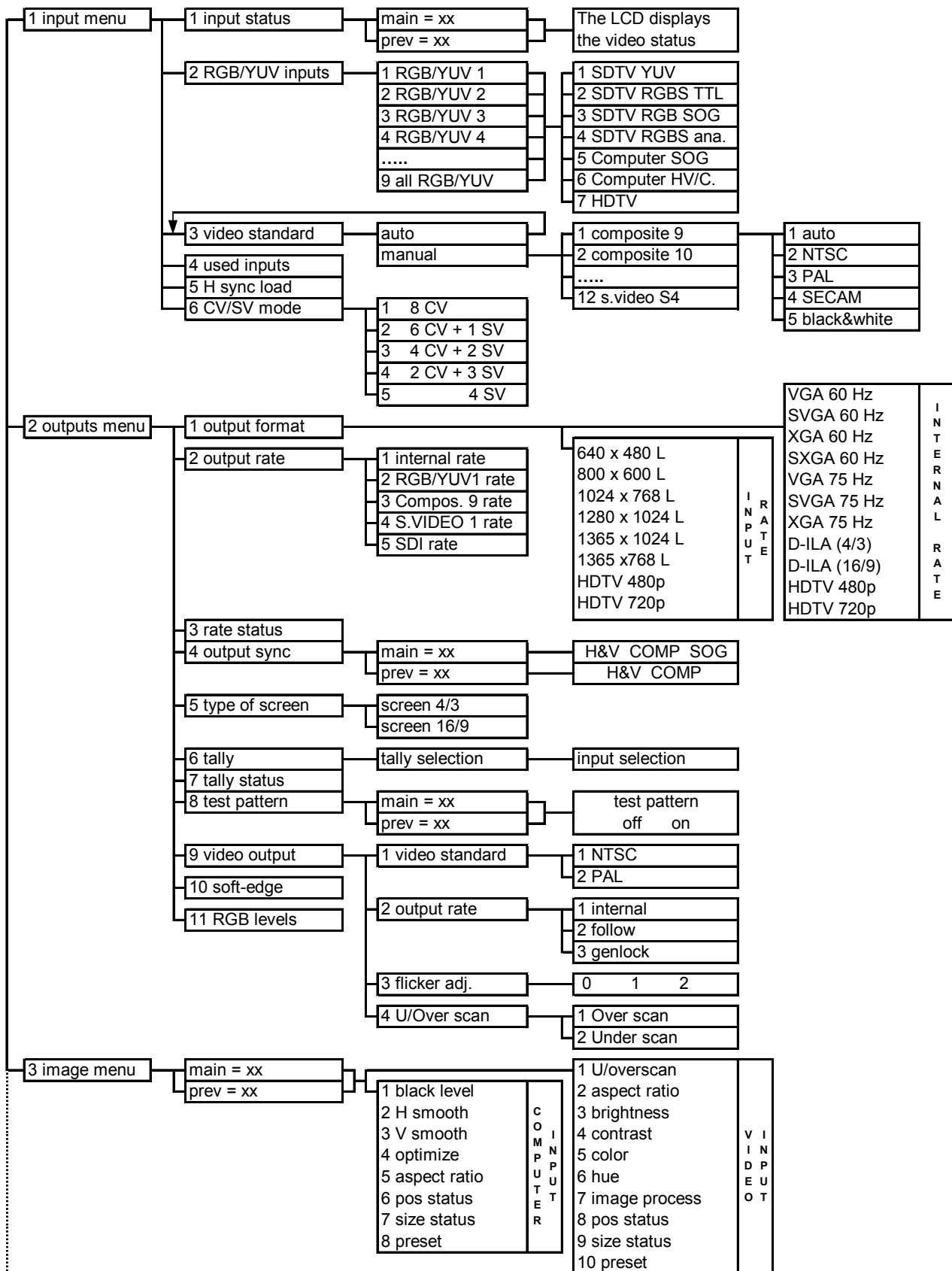

6-4. CONTROL MODE (continued)

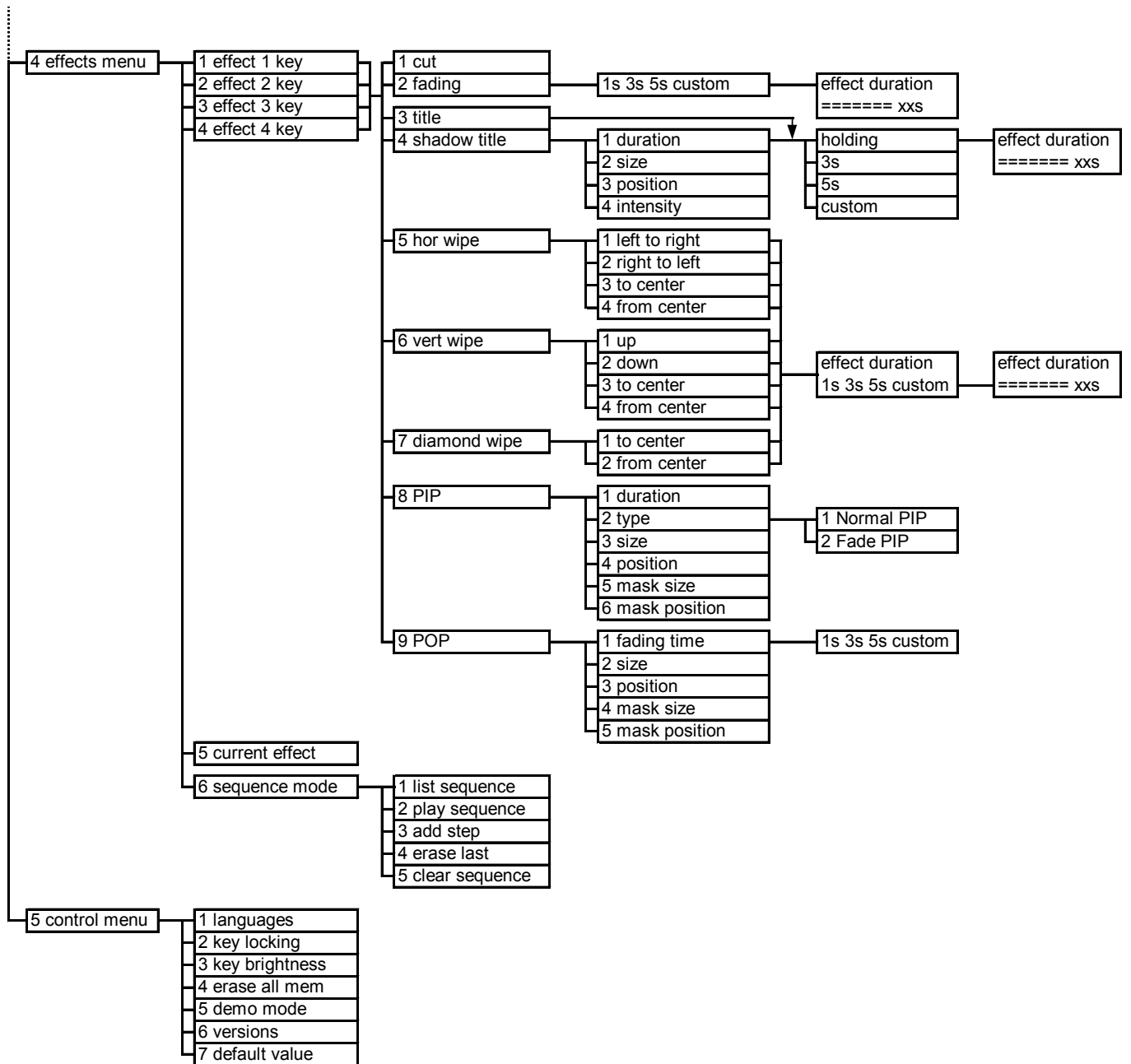

## **Chapter 7 : LCD FUNCTIONS DESCRIPTION**

### **1 ▶ [INPUT MENU] + ENTER.**

#### **1-1 [Input Status] + ENTER.**

Select [MAIN = x] or [PREV = x] with ◀ ▶ + **ENTER**.

- [MAIN = x] = Number of the selected input.
- [SYNC = xxxx] = Sync. type: [H+V+] = Separate H & V Sync. with polarities.  
[COMP] = Composite Sync.  
[SOG] = Sync. On Green.
- [XGA 48KHz/60Hz] = Name of the format, line / frame frequency [kHz/Hz], [i] = interlaced format.
- [NO INPUT] = No signal detected on this input.
- [OUT OF RANGE] = The input signal is not compatible with the input range of the device.

#### **1-2 [RGB/YUV inputs] + ENTER.**

① Select first the RGB/YUV inputs with ◀ ▶ + **ENTER**.

② Then select the signal connected to the input with ◀ ▶ + **ENTER** between:

- [SDTV YUV] = Component (YUV) video signal.
- [SDTV RGBS TTL] = RGB/S video signal with TTL Composite Sync.
- [SDTV RGB SOG] = RGsB video signal with analog Composite Sync. On Green.
- [SDTV RGBS ana.] = RGB/S with an analog Composite Sync. (0.3 Vp/p).
- [Computer SOG] = RGsB Computer signal (Sync. on Green).
- [Computer HV/C.] = RGBHV or RGBS Computer signals.
- [HDTV] = 720p & 1080i with bi-level sync only (RGBHV).

**NOTE** : SDTV means Standard Definition TV (15 kHz).

#### **1-3 [Video standard] + ENTER.**

Select an item with ◀ ▶ + **ENTER**.

- [auto] = Automatic recognition of the video standard for all inputs. NTSC / PAL / SECAM / Black & White are detected automatically; if not, please use the [manual] setting.
- [manual] = Manual selection of the video standard for each input.

① Select first an input with ◀ ▶ + **ENTER**.

② Then select the video standard with ◀ ▶ + **ENTER**.

- [auto] = Automatic detection.
- [NTSC] = NTSC detection only.
- [PAL] = PAL detection only.
- [SECAM] = SECAM detection only.
- [Black & White] = Black and White detection only.

#### **1-4 [Used inputs] + ENTER.**

This function allows to disable the unused input keys.

Select an input [#1, to SDI] with ◀ ▶ and press **ENTER** to change the selection.

- [#1 used] = Input #1 used (KEY 1 is low lighted).
- [#6 unused] = Input #6 unused (KEY 6 is OFF).

#### **1-5 [H sync load] + ENTER.**

Select [#1, #2, #3...] with ◀ ▶ and press **ENTER** to change the selection.

- [#1 75Ω load] = The H Sync. of the input #1 is set under 75 ohms.
- [#2 Hi-Z] = The H sync. of the input #2 is set under high impedance.

#### **1-6 [CV/SV mode] + ENTER.**

Select the COMPOSITE & S.VIDEO mode corresponding to your configuration.

- [8 CV ] = 8 COMPOSITE inputs (# 9 to 16) are enabled.
- [6 CV + 1 SV] = 6 COMPOSITE inputs (# 9 to 14) and 1 S.VIDEO inputs (# S1) are enabled.
- [4 CV + 2 SV] = 4 COMPOSITE inputs (# 9 to 12) and 2 S.VIDEO inputs (# S1 & S2) are enabled.
- [2 CV + 3 SV] = 2 COMPOSITE inputs (# 9 & 10) and 3 S.VIDEO inputs (# S1 to S3) are enabled.
- [ 4 SV] = 4 S.VIDEO inputs (# S1 to S4) are enabled.

**2 ▶ [OUTPUT MENU] + ENTER.****2-1 [output format] + ENTER.**

Select one of the following output format with ◀ ▶ + **ENTER**.

- If [output rate] = [internal rate], the LCD window displays the following formats :
  - [VGA 60 Hz] = 640 x 480 at 60 Hz
  - [SVGA 60 Hz] = 800 x 600 at 60 Hz
  - [XGA 60 Hz] = 1024 x 768 at 60 Hz
  - [SXGA 60 Hz] = 1280 x 1024 at 60 Hz.
  - [D-ILA - 4/3] = 1365 x 1024 at 75 Hz.
  - [D-ILA - 16/9] = 1365 x 768 at 75 Hz.
  - [HDTV 480p] = 853 x 480 at 60 Hz.
  - [HDTV 720p] = 1280 x 720 at 60 Hz.
  - [VGA 75 Hz] = 640 x 480 at 75 Hz.
  - [SVGA 75 Hz] = 800 x 600 at 75 Hz.
  - [XGA 75 Hz] = 1024 x 768 at 75 Hz.
- If [output rate] = [RGB/YUV1 rate], [compos.9 rate], [s.video1 rate], or [SDI rate] the LCD window displays the following formats:
  - [640 x 480 L] = Line doubler: 480p/59.94 Hz or 576p/50 Hz - 4/3.
  - [800 x 600 L] = 800 x 600 at 50 Hz or 59.94 Hz - 4/3.
  - [1024 x 768 L] = 1024 x 768 at 50 Hz or 59.94 Hz - 4/3.
  - [1280 x 1024 L] = 1280 x 1024 at 50 Hz or 59.94 Hz.
  - [1365 x 1024 L] = 1365 x 1024 at 50 Hz or 59.94 Hz - 4/3.
  - [1365 x 768 L] = 1365 x 768 at 50 Hz or 59.94 Hz - 16/9.
  - [HDTV 480p] = 853 x 480 at 50 Hz or 59.94 Hz - 16/9.
  - [HDTV720p] = 1280 x 720 at 50 Hz or 59.94 Hz - 16/9.

**NOTE:** The output rate is 50 Hz for PAL & SECAM video inputs, or 59.94 Hz for NTSC video inputs.

**NOTE:** For fixed pixels display device (DMD, LCD, PLASMA...), always select the output format corresponding to the native resolution of the display device. This way, the display device will not have to scale the image and the result will be better.

**2-2 [output rate] + ENTER.**

Select an item with ◀ ▶ + **ENTER**.

- [internal rate] = The output frame rate is 60 Hz or 75 Hz depending of the selected output format (LCD menu # 2-1). A higher frame frequency gives a better visual aspect when displaying static pictures.
- [RGB/YUV1 rate] = The output frame rate is identical to the RGB/YUV1 input frame rate : 50 Hz if the input video standard is PAL or SECAM and 59.94 Hz if the input video standard is NTSC. This function allows improving the motion pictures.
 

**NOTE:** If you select the [RGB/YUV1 rate] the LCD display the LCD menu #1-2. Verify or select the corresponding input format.
- [compos. 9 rate] = The output frame rate is identical to the COMPOSITE 9 input frame rate.
- [s.video 1 rate] = The output frame rate is identical to the S.VIDEO 1 input frame rate.
- [SDI rate] = The output frame rate is identical to the SDI input frame rate.

**2-3 [rate status] + ENTER.**

The LCD window displays the reference rate status.

- [compos. 9] = Referenced input for output rate.
- [50 Hz] = Output frame rate.

**2-4 [output sync] + ENTER**

This function allows selecting the sync type of the MAIN and PREVIEW outputs.

- ① First select the output [MAIN] or [PREV] with ◀ ▶ + **ENTER**.
- ② Then select the output Sync. type with ◀ ▶ + **ENTER**.
  - [H & V] = H & V separate Sync.
  - [COMP] = Composite Sync.
  - [SOG] = Sync. On Green (not available for the PREVIEW output).

**2-5[type of screen] + ENTER.**

Select an item with ◀ ▶ + **ENTER**.

- **[screen 4/3]** = if your image is displayed on a 4/3 wall mounted projection screen shape.
- **[screen 16/9]** = if your image is displayed on a 16/9 wall mounted projection screen shape.

**2-6[tally] + ENTER.**

① First select a tally output with ◀ ▶ + **ENTER** between:

② Then select an input for this tally output with ◀ ▶ + **ENTER**.

**2-7[tally status] + ENTER.**

The LCD window displays the status of the selected tally output. Select a tally output with ◀ ▶.

- **[ON]** = the tally output is active.
- **[OFF]** = the tally output is inactive.

**2-8[test pattern] + ENTER.**

This function allows displaying a test pattern for position and size adjustments.

① Select first the output [MAIN] or [PREV] with ◀ ▶ + **ENTER**.

② Then select one of the following functions with ◀ ▶ + **ENTER**.

- **[ON]** = Displays a test pattern on the selected output.
- **[OFF]** = Turns OFF the test pattern.

**2-9[video output] + ENTER. (THIS MENU IS ONLY AVAILABLE WITH THE OPTIONAL VIDEO OUTPUT).**

**NOTE:** The following functions act on the video outputs only (COMPOSITE VIDEO, S.VIDEO and COMPONENT).

**2-9-1 [video standard] + ENTER.**

Select the output standard for the video outputs with ◀ ▶ + **ENTER** between:

- **[NTSC]**
- **[PAL]**

**2-9-2 [output rate] + ENTER.**

Select a function with ◀ ▶ + **ENTER** between:

- **[internal]** = the video output is generated by the device (The output standard can be PAL or NTSC depending on the LCD menu #2-9-1).
- **[follow]** = the video output is synchronized onto the referenced input (Only if LCD menu # 2-2 is not **[internal rate]**. The video output standard can be PAL or NTSC depending on the standard of the referenced input).
- **[genlock]** = the video output is synchronized onto an external device. For this function you must:
  - Connect the supplied video cable to the DB9 connector (OPTIONAL VIDEO OUTPUT).
  - Connect the reference signal device to the "genlock input" yellow cable (BNC connector).

**2-9-3 [flicker adj.] + ENTER.**

Select a level of anti-flicker with ◀ ▶ + **ENTER**.

**2-9-4 [U/Over scan] + ENTER.**

Select the zoom mode with ◀ ▶ + **ENTER** between:

- **[underscan]** = Underscan mode. The entire image is visible on the screen. Computer display mode is underscan.
- **[overscan]** = Overscan mode. The image is displayed about 8 % bigger than in underscan mode, to avoid seeing the corners and the borders. Standard TV display mode is overscan.

**2-10 [soft-edge] + ENTER. (THIS MENU IS ONLY AVAILABLE WITH THE ADD-ON-1 UPGRADE).****2-11 [RGB levels] + ENTER.**

This function allows to adjust the RGB levels of the outputs. Select a color with ◀ ▶ + **ENTER** and adjust the level with ◀ ▶ + **ENTER**.

**3 ▶ [IMAGE MENU] + ENTER.**

**NOTE:** The IMAGE adjustments act on the selected and/or the pre-selected input. Select [MAIN] to adjust the image displayed on the MAIN output and select [PREV] to adjust the image displayed on the PREVIEW output.

**• If the selected input is a COMPUTER signal (LCD menu # 1-2 = Computer---) the IMAGE MENU displays the following items :**

**3-1 [Black level] + ENTER.**

Adjust the black level with ◀ ▶ + ENTER.

**3-2 [H. smooth] + ENTER.**

- [ON] = Vertical smoothing active.
- [OFF] = Vertical smoothing inactive.

**3-3 [V. smooth] + ENTER.**

- [ON] = Horizontal smoothing active.
- [OFF] = Horizontal smoothing inactive.

**3-4 [optimize] + ENTER.**

[#3 optimize] = Optimization of the input #3 image.

**3-5 [aspect ratio] + ENTER.**

Select the Aspect Ratio of your input source with ◀ ▶ + ENTER.

- [4/3 standard] = 4/3 input format.
- [letterbox] = Letterbox input format.
- [16/9] = 16/9 input format.

**3-6 [pos status] + ENTER.**

Display the horizontal and vertical position status.

**3-7 [size status] + ENTER.**

Display the horizontal and vertical size status.

**3-8 [preset] + ENTER.**

This function allows setting all the image parameters to the factory settings. Select [YES] and validate with ENTER.

**• If the selected input is a VIDEO signal (COMPOSITE, S.VIDEO, COMPONENT, RGsB or RGBS) the IMAGE MENU display the following items :**

**3-1 [U / Overscan] + ENTER.**

Select an item with ◀ ▶ + ENTER.

- [underscan] = Underscan mode. The entire image is visible on the screen. Computer display mode is underscan.
- [overscan] = Overscan mode. The image is displayed about 8 % bigger than in underscan mode, to avoid seeing the corners and the borders. Standard TV display mode is overscan.

**3-2 [aspect ratio] + ENTER.**

Select the Aspect Ratio of your input source with ◀ ▶ + ENTER.

- [4/3 standard] = 4/3 input format.
- [letterbox] = Letterbox input format.
- [WS anamorphic] = Wide Screen anamorphic input format.

**3-3 [brightness] + ENTER.**

Adjust the brightness with ◀ ▶ + ENTER.

**3-4 [contrast] + ENTER.**

Adjust the contrast with ◀ ▶ + ENTER.

**3-5[*color*] + ENTER**

Adjust the color with ◀ ▶ + **ENTER**.

**3-6[*hue*] + ENTER.**

Adjust the tint of the picture (NTSC video sources only) with ◀ ▶ + **ENTER**.

**3-7[*image process*] + ENTER.**

Select a level of process with ◀ ▶, and validate with **ENTER**.

**3-8[*pos status*] + ENTER.**

Display the horizontal and vertical position status.

**3-9[*size status*] + ENTER.**

Display the horizontal and vertical size status.

**3-10 [*preset*] + ENTER.**

This function allows setting all the image parameters to the factory settings. Select [**YES**] and validate with **ENTER**.

**4 ▶ [EFFECT MENU]**

This menu allows to store an effect in the 4 Effect memory keys (front panel keys).

① First select an effect key with ◀ ▶ + **ENTER** between:

**4-1 [effect 1 key]**

**4-2 [effect 2 key]**

**4-3 [effect 3 key]**

**4-4 [effect 4 key]**

② Then select one of the following effects:

**4-x-1 [cut]** = allows to switch seamlessly the pre-selected input onto the MAIN output.

**4-x-2 [fading]** = allows to fade the pre-selected input to the MAIN output . You can select the duration of the transition as indicated below :

- **[1s]** = 1 second transition.
- **[3s]** = 3 seconds transition.
- **[5s]** = 5 seconds transition.
- **[custom]** = allows to select a duration from 0.5 second up to 25 seconds by 0.5 second steps.

**4-x-3 [title]** = allows to overlay a title on the MAIN output . The title should be done with drawn standard software (Paint, PowerPoint...) in white color on a black background . You can select the duration of this effect between:

- **[holding]** = the text appears after pushing on the TAKE key, and will be removed only by a second push on the TAKE key.
- **[3s]** = 3 seconds transition.
- **[5s]** = 5 seconds transition.
- **[custom]** = allows to select a duration from 0.5 second up to 25 seconds by 0.5 second steps.

**4-x-4 [shadow title]** = Same function as **[title]** but a shadow bar appears at the bottom of the image. This function allows increasing the readability of the text on bright images.

① Select the **[duration]** of the transition with ◀ ▶ + **ENTER** between :

- **[holding]** = the text appears after pushing on the TAKE key, and will be removed only by a second push on the TAKE key.
- **[3s]** = 3 seconds transition.
- **[5s]** = 5 seconds transition.
- **[custom]** = allows to select a duration from 0.5 second up to 25 seconds by 0.5 second steps.

② Select the **[size]** of the shadow bar with ◀ ▶ + **ENTER**.

③ Select the vertical **[position]** of the shadow bar with ◀ ▶ + **ENTER**.

④ Select the **[intensity]** of the shadow with ◀ ▶ + **ENTER**.

**4-x-5 [hor. wipe]** = allows to switch the pre-selected input onto the MAIN output with a horizontal wipe effect.

① First select an horizontal wipe effect with ◀ ▶ + **ENTER** between:

- [left to right]



- [right to left]



- [to center]



- [from center]



② Then select the duration of the transition.

- [1s] = 1 second transition.
- [3s] = 3 seconds transition.
- [5s] = 5 seconds transition.
- [custom] = allows to select a duration from 0.5 second up to 25 seconds by 0.5 second step.

**4-x-6 [vert wipe]** = allows to switch the pre-selected input onto the MAIN output with a vertical wipe effect.

① First select an vertical wipe effect with ◀ ▶ + **ENTER** between:

- [up]



- [down]



- [to center]



- [from center]



② Then select the duration of the transition.

- [1s] = 1 second transition.
- [3s] = 3 seconds transition.
- [5s] = 5 seconds transition.
- [custom] = allows to select a duration from 0.5 second up to 25 seconds by 0.5 second step.

**4-x-7 [diamond wipe]** = allows to switch the pre-selected input onto the MAIN output with a diamond wipe effect.

① First select a diamond wipe effect with ◀ ▶ + **ENTER** between:

- [to center]



- [from center]



② Then select the duration of the transition.

- [1s] = 1 second transition.
- [3s] = 3 seconds transition.
- [5s] = 5 seconds transition.
- [custom] = allows to select a duration from 0.5 second up to 25 seconds by 0.5 second steps.

**NOTE: THIS EFFECT IS NOT AVAILABLE WITH THE ADD-ON-1 UPGRADE.**





**4-x-8 [PIP]** = allows to display a picture into another picture. The PREVIEW image is reduced and displayed onto the MAIN image.

- ① Select the **[duration]** of the transition , and validate with **ENTER**.
  - **[holding]** = the PREVIEW image appears after pushing on the TAKE key, and will be removed only by a second push on the TAKE key.
  - **[3s]** = 3 seconds transition.
  - **[5s]** = 5 seconds transition.
  - **[custom]** = allows to select a duration from 0.5 second up to 25 seconds by 0.5 second steps.
- ② Select the **[type]** of PIP with ◀ ▶ + **ENTER**.
  - **[normal PIP]** = The PIP appears onto the MAIN output with a cut effect.
  - **[fade PIP]** = The PIP appears onto the MAIN output with a fade effect.
- ③ Select the **[size]** of the PIP (between 15 and 100%) with ◀ ▶ (or with **H** and **V**), and validate with **ENTER**.
- ④ Set the horizontal and vertical **[position]** of the PIP windows with the H and V knobs, and validate with **ENTER**.
- ⑤ Adjust the **[mask size]** with H and V knobs, and validate with **ENTER**. This function allows, for example, cutting the black bars of a letterbox source.
- ⑥ Adjust the **[mask position]** with the H and V knobs, and validate with **ENTER**.

**4-x-9 [POP]** = allows to change the background image when an image is inserted into another one. The transition operates with a fading to black.

- ① Select the fading duration with **[fade duration]**, and validate with **ENTER**.
  - **[1s]** = 1 second transition.
  - **[3s]** = 3 seconds transition.
  - **[5s]** = 5 seconds transition.
  - **[custom]** = allows to select a duration from 0.5 second up to 25 seconds by 0.5 second steps.
- ② Select the **[size]** of the POP (between 15 and 100%) with ◀ ▶ (or with **H** and **V**), and validate with **ENTER**.
- ③ Set the horizontal and vertical **[position]** of the POP windows with the H and V knobs, and validate with **ENTER**.
- ④ Adjust the **[mask size]** with H and V knobs, and validate with **ENTER**. This function allows, for example, cutting the black bars of a letterbox source.
- ⑤ Adjust the **[mask position]** with the H and V knobs, and validate with **ENTER**.

**NOTE:** The POP effect can not be use as extended effect in multi-screen application of the ADD-ON-1 upgrade.

#### 4-5 [current effect]

The LCD screen displays the current effect.

**NOTE:** The current effect can be directly displayed on the LCD screen by pressing the effect key.

**4-6 [sequence mode] + ENTER.**

This mode allows programming a sequence of transition. The sequence can also be activated at any time during the show, and controlled step by step (one step = pre-selection + transition) by one key only: the **STEP** key. This function allows to simplify the use of the device during a show.

**4-6-1 [list sequence] + ENTER.**

This function allows to verify the programmed sequence. Turn the ◀ ▶ knob to display the list.

**4-6-2 [play sequence] + ENTER.**

This function allows to **start** or **stop** the programmed sequence.

**IMPORTANT:** Before starting, verify that the correct input is displayed onto the MAIN output.

- ① Select **start** with ◀ ▶ and press **ENTER** to start the programmed sequence. The **STEP** key is blinking and the first pre-selected source is displayed onto the PREVIEW output. Press the **STEP** key to execute the first transition and pre-select the next source and so on.

**NOTE:** For **holding** effect (i.e. : holding PIP): the first push on **STEP** allows to activate the effect and a second push on **STEP** stops the effect.

- ② To **stop** the sequence press **ENTER**, the LCD menu displays **[play sequence]**: select **stop** with ◀ ▶ and validate with **ENTER**. The **STEP** key turns OFF.

**4-6-3 [add step] + ENTER.**

This function allows to add a step into your sequence. A step is composed of an input pre-selection and a transition. Each new step is added at the end of your sequence.

**Proceed as follow:**

- ① Select **start** and validate with **ENTER**. The **STEP** key turns ON.
- ② Pre-select an input with the input selection keys (the key is blinking and the image appears onto the PREVIEW output).
- ③ Select a transition: Press one of the four effect keys (1, 2, 3, 4) and select the needed effect.
- ④ Press on **STEP** to add this new **STEP** into your sequence. The transition is displayed onto the MAIN output.

**NOTE:** For **holding** effect (i.e. : holding PIP): the first push on **STEP** allows to activate the effect and a second push on **STEP** to stops the effect.

- ⑤ Repeat the operations ②, ③, ④ to add any new steps.

**NOTE:** You can add up to 40 STEPS into your sequence.

- ⑥ Select **stop** to deactivate the **add step** function. The **STEP** key turns OFF.

**4-6-4 [erase last] + ENTER.**

Erases the last step of the sequence.

**4-6-5 [clear sequence] + ENTER.**

Erases all of the sequence.

5 ▶ [CONTROL MENU]

5-1 [languages]

5-2 [key locking] + ENTER.

Select which locking function you need with ◀ ▶ + ENTER.

- [input] = Lock or unlock the input keys.
- [adjust] = Lock or unlock the adjust functions.
- [effects] = Lock or unlock the effect key.
- [control] = Lock or unlock the LCD control key.
- [freeze] = Lock or unlock the FREEZE keys.

**NOTE:** To unlock the control key, pushes simultaneously on ENTER and EXIT.

5-3 [key brightness] + ENTER.

Select the level of the key brightness with ◀ ▶ + ENTER.

5-4 [erase all mem] + ENTER.

This function allows erasing all the NON-volatile image memories. Select [YES] and validate with ENTER.

5-5 [demo mode] + ENTER.

This mode allows playing a sequence of effect every 4 seconds. Select [YES] and validate with ENTER.

5-6 [versions] + ENTER.

Display the status of the internal firmware.

- A = xxxx
- B = xxxx
- X = xxxx
- Y = xxxx
- S = xxxx
- D = xxxx
- K = xxxx
- V = xxxx (optional)
- I = Identification number.

5-7 [default value] + ENTER.

This function allows setting all the image parameters to the factory settings. Select [YES] and validate with ENTER. Then switch OFF and ON the device.

FUNCTION	POSITION	FUNCTION	POSITION
1-2 RGB/YUV inputs	computer HV/C	2-8 test pattern	OFF (main and preview).
1-3 video standard	auto	2-9-1 video standard	NTSC.
1-4 used Inputs	used	2-9-2 output rate	internal.
1-5 H Sync Load	Hi-Z	2-9-3 flicker adjustment	0.
1-6 CV/SV mode	4 CV + 2 SV	2-9-4 U/Overscan	Over scan.
2-1 output format	XGA 60Hz	4-1 effect 1 key	cut
2-2 output rate	internal rate	4-2 effect 2 key	fading 3.0s
2-4 output sync	separate H & V	4-3 effect 3 key	hold. title man.
2-5 type of screen	screen 4/3	4-4 effect 4 key	diamond in 3.0s
2-6 tally	tally 1 = RGB/YUV 1	5-2 key locking	OFF
	tally 2 = compos. 9	5-3 key brightness	3
	tally 3 = s.video 1		
	tally 4 = SDI.		

## **Chapter 8 : UPDATING THE GRAPHIC SWITCHER II™**

The GRAPHIC SWITCHER II™ can be update thanks a COMPUTER (PC) via its REMOTE (RS-232) connector.

### **8-1. CONNECTIONS:**

- ① Connect the "REMOTE RS-232 & TALLY OUT" connector of the GRAPHIC SWITCHER II™ to the SERIAL port of your COMPUTER with a DB9 M/F straight cable.
- ② Connect the GRAPHIC SWITCHER II™ to an AC power outlet.
- ③ Switch OFF the GRAPHIC SWITCHER II™ (REAR PANEL SWITCH = O).

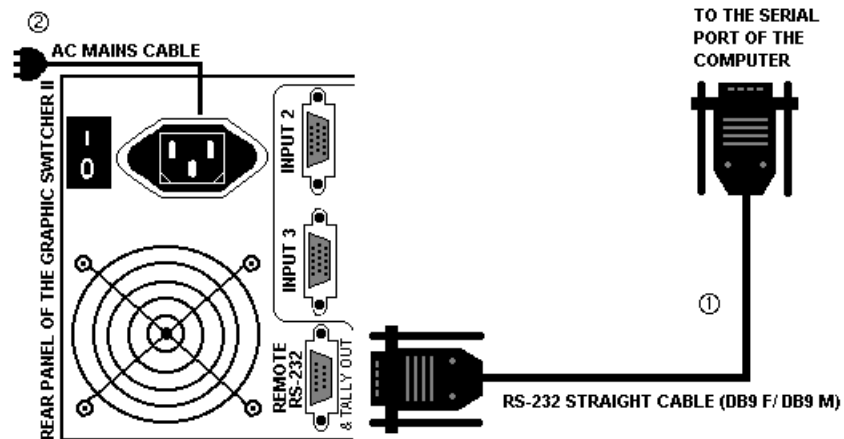

### **8-2. UPDATE INSTRUCTIONS:**

- ① Open the file "Analog way GSW2811R updater" (in start/Program/ANALOG WAY/GSW2811R).
- ② Click on "START" on the SOFTWARE.
- ③ Press the ENTER button of the GRAPHIC SWITCHER II™ (FRONT PANEL), and SWITCH it ON simultaneously (REAR PANEL SWITCH = I ). All front panel keys switch ON and OFF, the LCD screen displays Downloading, and the update will start. Then you can release the ENTER button.
- ④ When the software displays "Program operation completed", SWITCH OFF and ON the GRAPHIC SWITCHER II™ with the REAR PANEL SWITCH.
- ⑤ Click on the "Quit" button to close the update software.

**NOTE:** YOUR GRAPHIC SWITCHER II™ IS NOW READY TO WORK.

**NOTE:** THE UPDATER FILES ARE AVAILABLE ON OUR WEB SITE: [www.analogway.com](http://www.analogway.com)

**Chapter 9 : CONTROL SOFTWARE**

**9-1. CONNECTION**

**• CONNECTING THE RS-232**

Connect the serial port of your controlling device to the REMOTE RS-232 connector of the GRAPHIC SWITCHER II™ with a **straight** cable (DB9 pins female / DB9 pins male).

**• PIN-OUT**

PIN #	FUNCTION
2	TRANSMIT DATA (Tx)
3	RECEIVE DATA (Rx)
5	GROUND (Gnd)

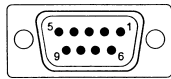

DB 9 female connector  
(Rear panel of the GRAPHIC SWITCHER II™)

**• SPEED TRANSMISSION :** 9600 bauds, 8 data bits, 1 stop bit, no parity bit, no flow control.

**9-2. "GRAPHIC SWITCHER II™ CONTROL PANEL" SOFTWARE**

Your GRAPHIC SWITCHER II™ is shipped with a WINDOWS 95/98/2000/Me/XP compatible "GRAPHIC SWITCHER II™ REMOTE CONTROL" software (3.5" disk). This software allows you to control and make adjustments by a simple mouse click (output format, image adjustments, etc...).

**• SOFTWARE INSTALLATION:**

- ① Turn your computer ON and wait for WINDOWS to completely start.
- ② Insert the disk into the floppy drive.
- ③ In the WINDOWS START menu, click on RUN.
- ④ Choose the disk drive and click on **setup.exe** (ex : A:\**setup.exe** if disk 3.5" is drive A).
- ⑤ Follow the WINDOWS installation instructions. WINDOWS will create a file C:\Programfiles\ANALOGWAY\Graphic switcher II remote control.

**• STARTING UP:**

- ① Connect the RS-232 cables between the controlling device and the GRAPHIC SWITCHER II™ as indicated in section 9-1.
- ② Then only power ON all of the devices.
- ③ Click on the program files **GSW2811** in **Start-program-ANALOGWAY-GRAPHIC SWITCHER II** to run the software.
- ④ Click on **Control** menu and select the **Serial port**.

The GRAPHIC SWITCHER II™ is now controllable by the computer.

9-3. SOFTWARE SET UP

- ① Select the **Serial port** in the **Control** menu.

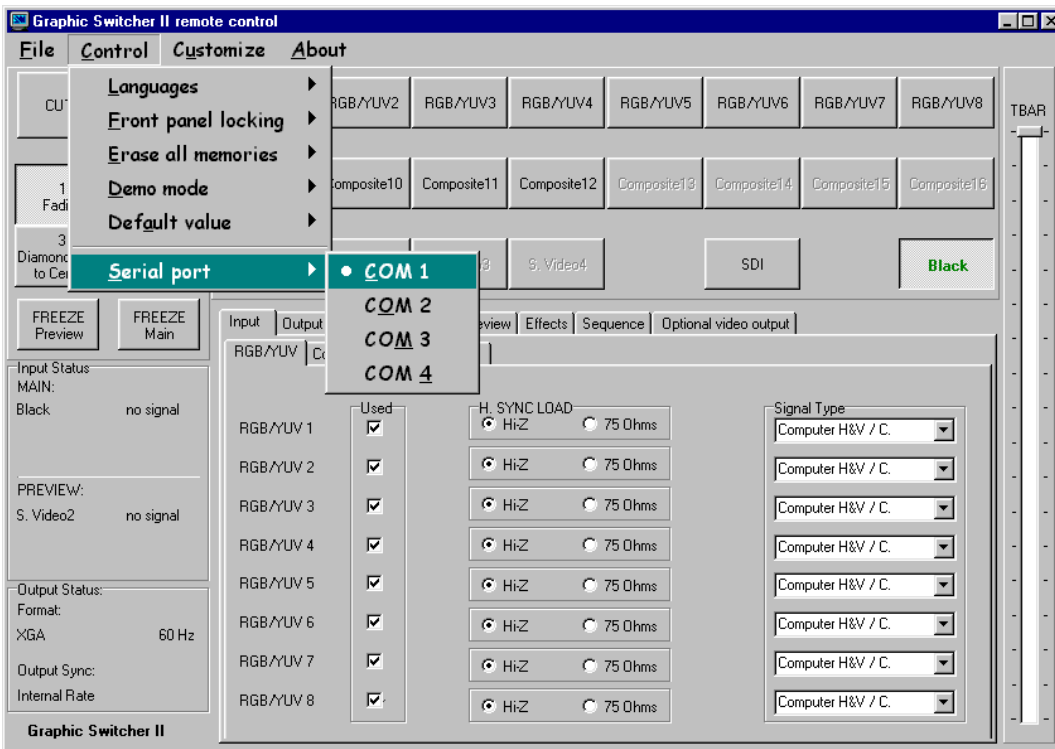

The GRAPHIC SWITCHER II™ is now connected to the computer.

- ② In the **Input** menu:
  - Select the type of signal connected to the **RGB / YUV** inputs (RGB/YUV section).
  - Select the **COMPOSITE & S.VIDEO** mode corresponding to your configuration (Composite & S.Video section).
  - Select if necessary, the standard of the Composite & S.Video sources (Composite & S.Video section).
  - Disable the unused input keys.

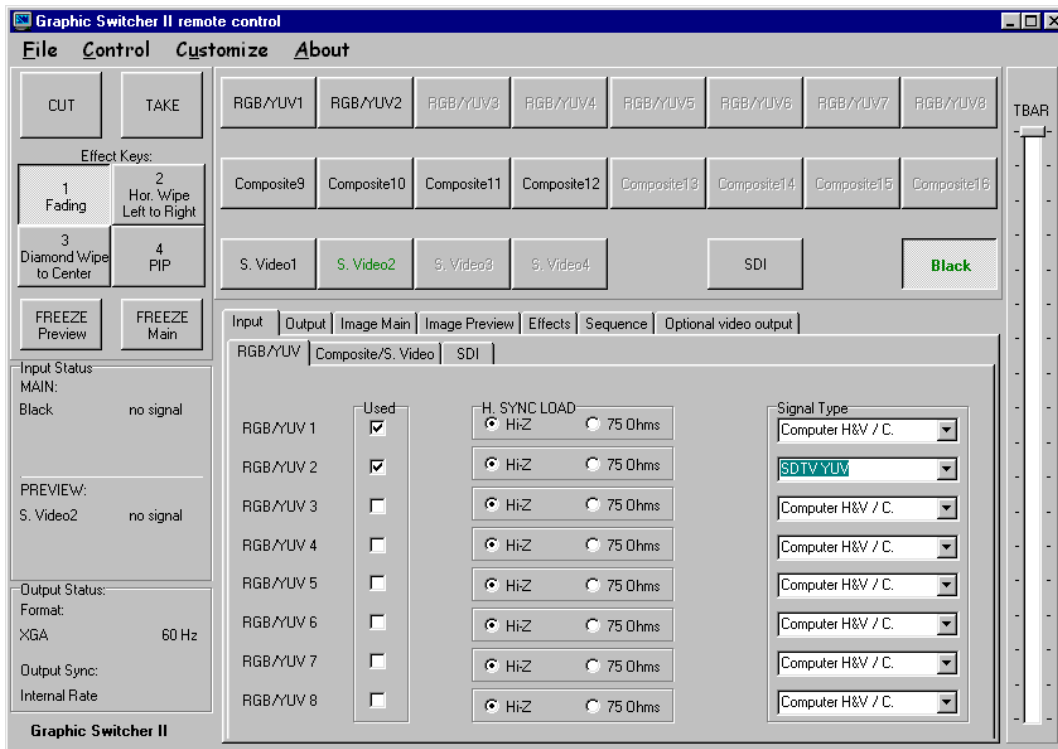

**NOTE** : **Auto** = Automatic recognition of the video standard.



9-3. SOFTWARE SET UP (continued)

- ③ In the **Output** menu, select the **Output rate**, the **Output format**, the **Output Sync** and the **TALLY** outputs.

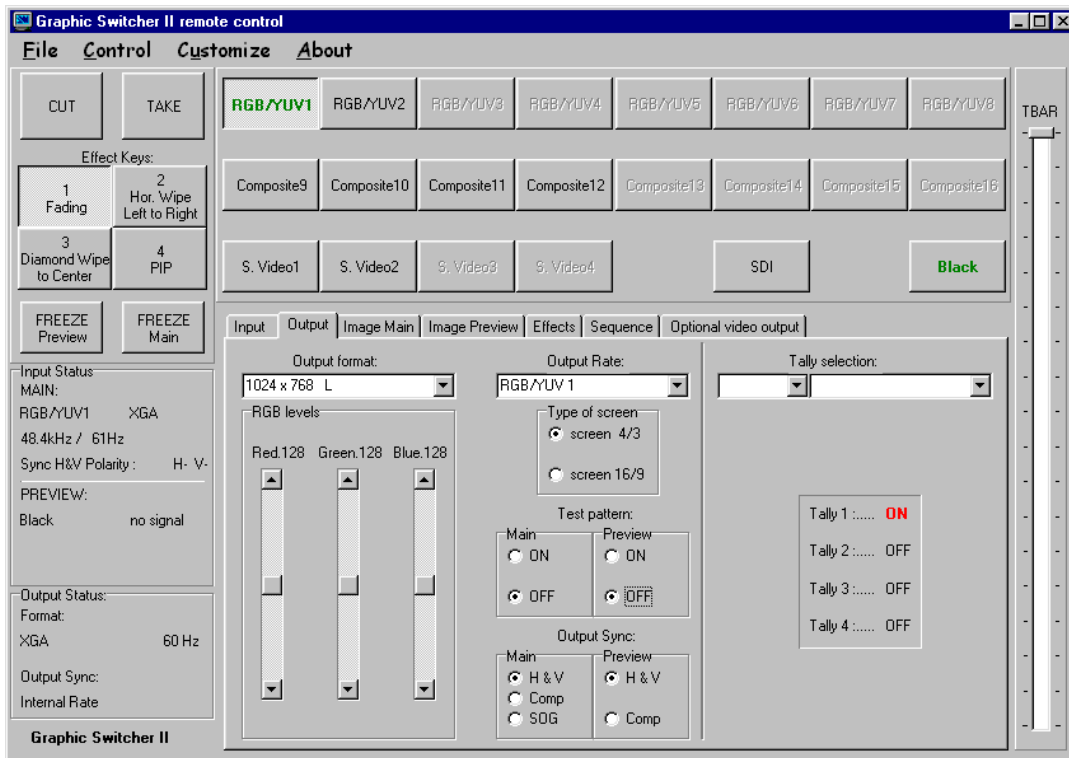

- ④ **Image** menus (MAIN & PREVIEW):

- If a video source is selected the image menu display the following parameters:

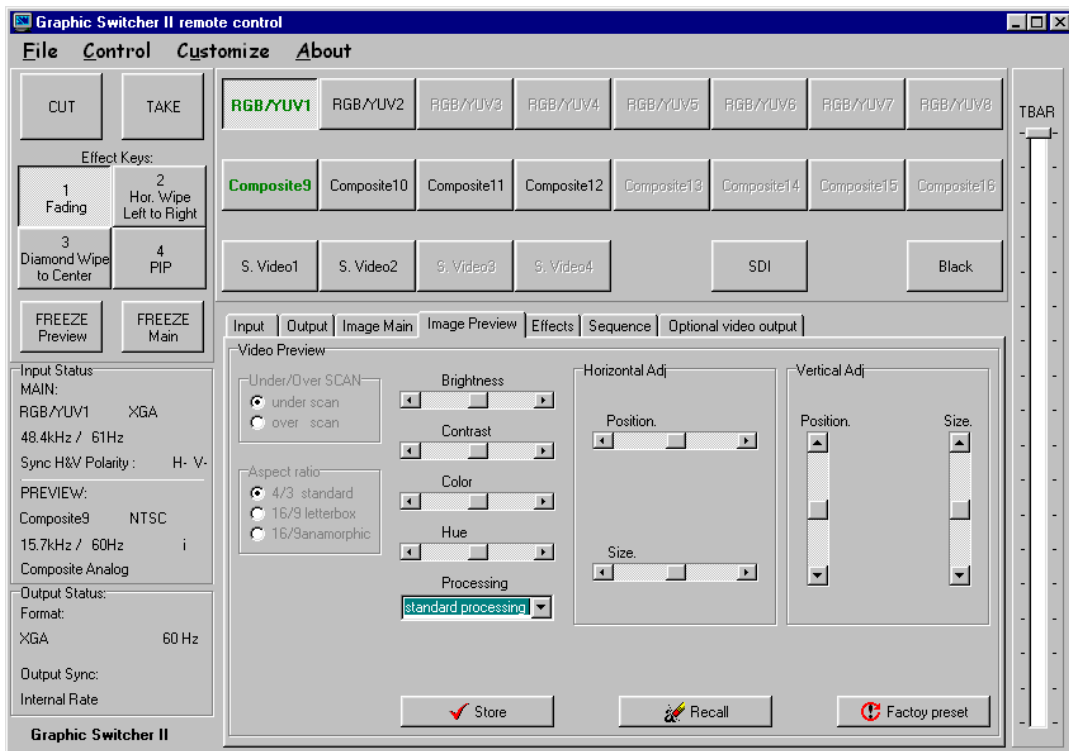

- Adjust the position and the size of the image. If needed, do the others adjustments available in this menu.
- Click on **STORE** to memorize the adjustments.

**NOTE:** The **RECALL** function allows setting the stored image settings.  
The **FACTORY PRESET** function sets all of the **Image** adjustments to the factory settings.

9-3. SOFTWARE SET UP (continued)

④ Image menus (continued):

- If a computer source is selected the image menu display the following parameters:

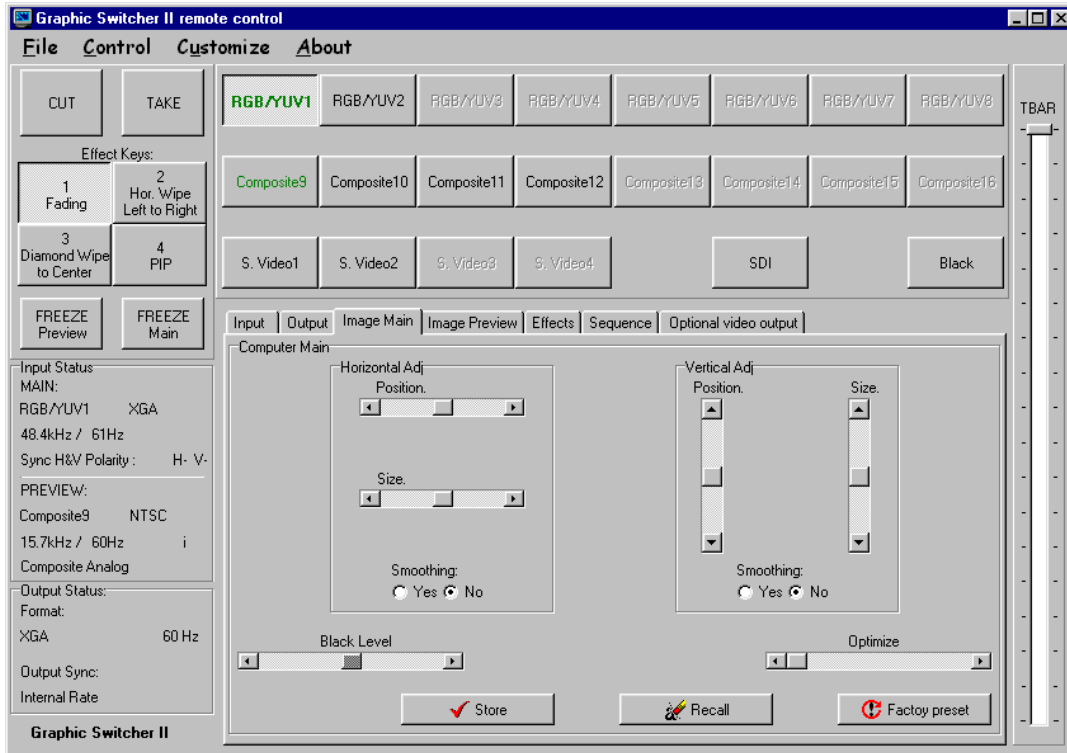

⑤ Effects menu: This menu allows to store effects in the Effects Keys.

- Select an Effect Key (1, 2, 3, or 4).
- Select one of the effects available in the Effects menu.
- Then adjust the options of the selected effect (duration, size...).

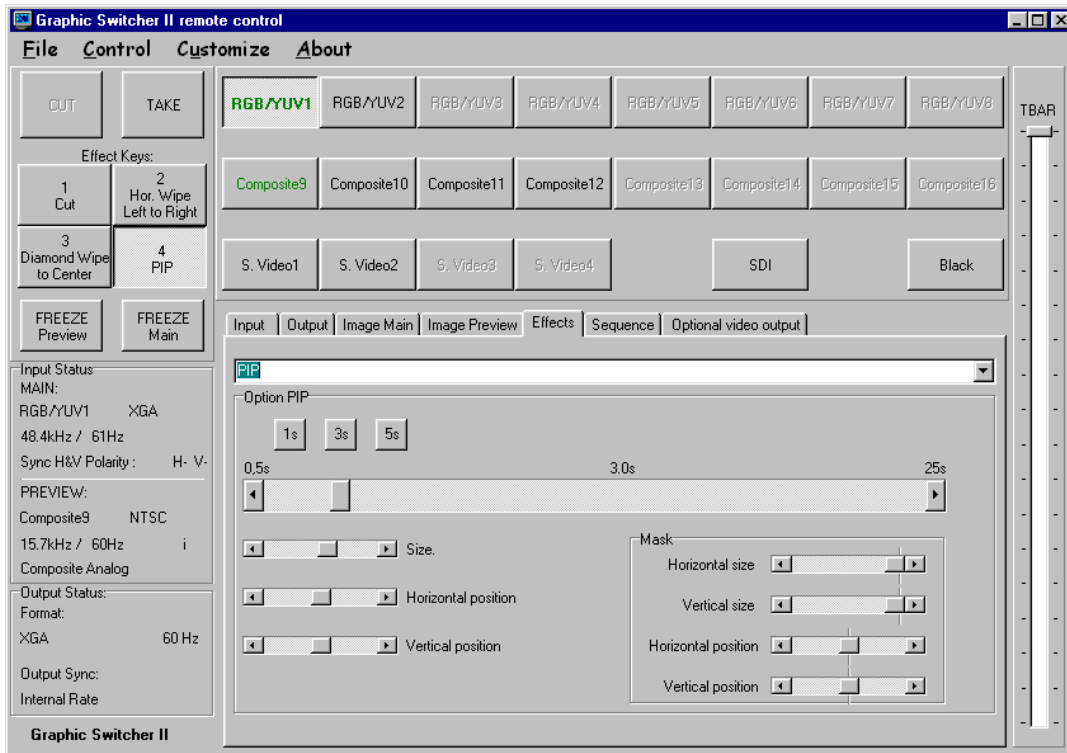



9-3. SOFTWARE SET UP (continued)

⑥ **Sequence** menu:

This mode allows programming a sequence of transition. The sequence can also be activated at any time during the show, and controlled step by step (one step = pre-selection + transition) by one key only: the **STEP** key.

• **TO PROGRAM A SEQUENCE:**

- 1 - Click on **Add** button in the **Edit Sequence** section to start the Add step function.
- 2 - Pre-Select an input source and select a transition (Effects Keys).
- 3 - Click on **STEP** button to add the step at the end of your sequence. The transition is displayed onto the MAIN output and the description of the step is added in the table.  
**NOTE:** For **holding** effect (i.e. : holding PIP): the first push on **STEP** allows to activate the effect and a second push on **STEP** stops the effect.
- 4 - Renew the operations 2 and 3 to add new steps on your sequence.
- 5 - Click on **Stop** button in the **Edit Sequence** section to stop the Add Step function.

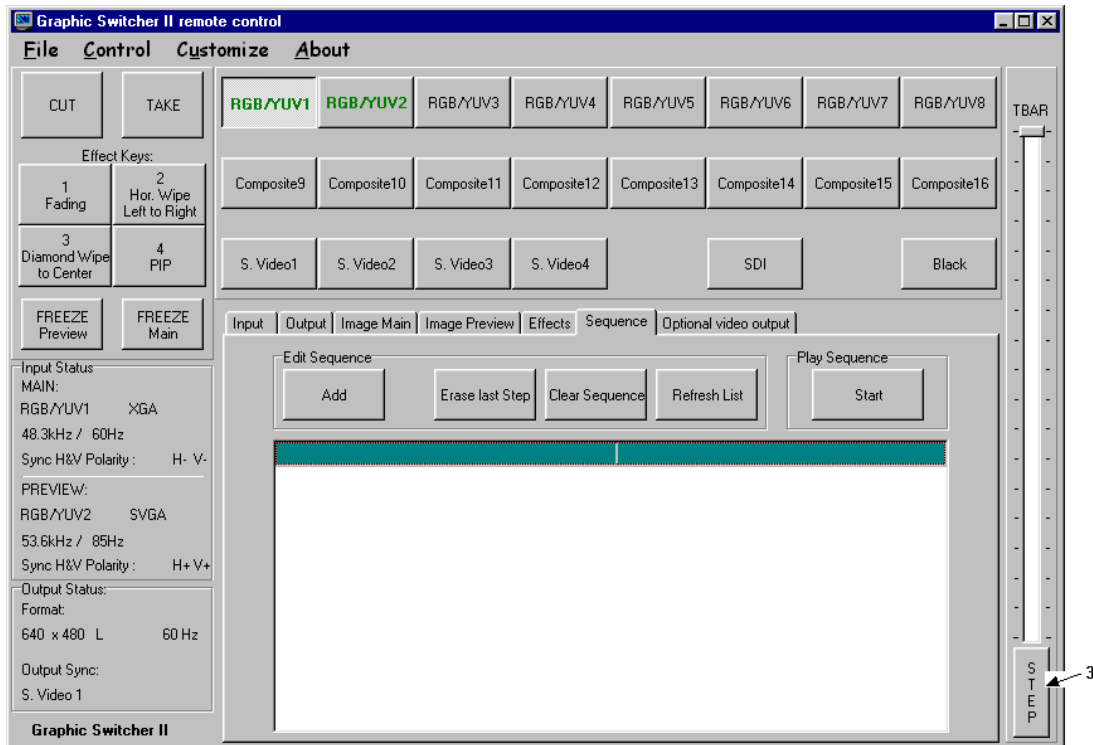

• **TO PLAY A SEQUENCE:**

- 1 - Click on **Start** button in the **Play Sequence** section.
- 2 - Click on **STEP** button to execute the first transition and pre-select the next source and so on.
- 3 - Click on **Stop** button in the **Play Sequence** section to stop the Play sequence function.

⑦ **Optional video output** menu. **THIS MENU IS AVAILABLE ONLY WITH THE OPTIONAL VIDEO OUTPUT.** The following functions act on the video outputs only (COMPOSITE VIDEO, S.VIDEO and COMPONENT). See Chapter 7 : menu # 2-8 for the description of these functions.

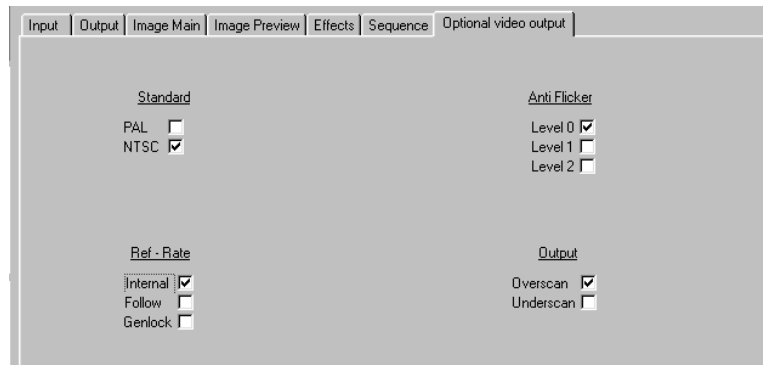

## **Chapter 10 : RS-232 PROGRAMMER'S GUIDE**

### 10-1. INTRODUCTION

If you need to use your own Control Software from a PC, or WORKSTATION with an RS-232 port, the GRAPHIC SWITCHER II™ allows communicating through an ASCII code protocol.

The GRAPHIC SWITCHER II™ treats any character received on its RS-232 as a possible command but, it only accepts legal commands. There is no starting/ending in a command string.

A command can be 1 or 2 characters typed on a keyboard and does not require any special characters before or after it. (it is not necessary to press "ENTER" on the keyboard). A command can be preceded by a value (see chapter 10-2. COMMANDS STRUCTURE).

When the GRAPHIC SWITCHER II™ receives a valid command, it will execute the command. Then it will send back the status of all the parameters that have changed due to this command from the control device.

For example: When you pre-select an input the GRAPHIC SWITCHER II™ indicates the input that you have pre-selected and the status of all its parameters (input standard, image adjustment,...)

If the command cannot be executed (value out of range, no signal on the selected input), the GRAPHIC SWITCHER II™ just send back the current status of the corresponding parameters.

If the command is invalid, an error response will be returned to the controlling device. All responses sent to the controlling device end with a carriage return <CR> and a line feed <LF> signaling the end of the response character string. (see chapter 10-3. ERROR RESPONSES).

### 10-2. COMMANDS STRUCTURE

Commands are usually composed of a numerical value followed by the command characters (1 or 2). The characters used without any numerical value return the current setting of the command.

COMMAND structure = VALUE (optional) + CHARACTER(S)

Examples:

COMMAND		RESPONSE	DESCRIPTION
VALUE	CHARACTER(S)		
none	fm	OSYN0	Read the Sync type of the MAIN output.
10	V	VP10	Set Vertical position to 10.

### 10-3. ERROR RESPONSES

When the GRAPHIC SWITCHER II™ receives from the controlling device an invalid command or value, it returns an error response:

COMMAND		RESPONSE	DESCRIPTION
VALUE	CHARACTER(S)		
none	BB	E10	Invalid command.
70260	V	E13	Invalid value.

10-4. COMMANDS AND RESPONSES TABLE

The following table resumes all of the commands that are recognized as valid and the responses that will be returned to the control device.

ASCII COMMAND	RESPONSE	COMMAND DESCRIPTION	TYPE	VALUE		
				MIN	MAX	DESCRIPTION
<b>FRONT PANEL COMMANDS</b>						
C	CH	MAIN selected input (read only).	Rd	0	21	Please see value description (next section).
c	ch	Input pre-selection (PREVIEW).	Rd/Wr	0	21	Please see value description (next section).
G	TAKE	TAKE (transition).	Rd/Wr	0	1	1 = start the transition (automatic reset at the end of the effect duration). 0 = stop the transition (for holding effect).
Z	FRZ	FREEZE MAIN.	Rd/Wr	0	1	0 = inactive      1 = active.
z	frz	FREEZE PREVIEW.	Rd/Wr	0	1	0 = inactive      1 = active.
M	STO	STORE (MAIN).	Rd/Wr	0	1	1 = STORE action (automatic reset).
m	sto	STORE (PREVIEW).	Rd/Wr	0	1	1 = STORE action (automatic reset).
R	REC	RECALL (MAIN).	Rd/Wr	0	1	1 = RECALL action (automatic reset).
r	rec	RECALL (PREVIEW).	Rd/Wr	0	1	1 = RECALL action (automatic reset).
H	HP	Horizontal position (MAIN).	Rd/Wr	0	255	
h	hp	Horizontal position (PREVIEW).	Rd/Wr	0	255	
V	VP	Vertical position (MAIN).	Rd/Wr	0	255	
v	vp	Vertical position (PREVIEW).	Rd/Wr	0	255	
W	HW	Horizontal size (MAIN).	Rd/Wr	0	255	
w	hw	Horizontal size (PREVIEW).	Rd/Wr	0	255	
S	VS	Vertical size (MAIN).	Rd/Wr	0	255	
s	vs	Vertical size (PREVIEW).	Rd/Wr	0	255	
<b>INPUT COMMANDS</b>						
PC	PCH	Input selection for adjustment.	Rd/Wr	0	21	Please see value description (next section).
PE	PEN	Input disabling (works with PC)	Rd/Wr	0	1	0 = Input disable      1 = Input enable.
PL	PLD	H sync load selection (works with PC).	Rd/Wr	0	1	0 = Hi-Z load      1 = 75Ω load.
PR	PRGB	RGB input type selection (works with PC command).	Rd/Wr	0	6	0 = SDTV YUV      4 = computer (SOG) 1 = SDTV RGBS (TTL)      5 = comp (HV or C.) 2 = SDTV RGSB (SOG)      6 = HDTV. 3 = SDTV RGBS (ana)
PI	PSTD	Input standard selection (works with PC command).	Rd/Wr	0	4	0 = automatic standard detection. 1 = NTSC.      2 = PAL. 3 = SECAM      4 = Black & White.
ys	ISHR	Composite or S.VIDEO mode selection.	Rd/Wr	0	4	0 = 8 CV      3 = 2 CV + 3 SV 1 = 6 CV + 1 SV      4 =      4 SV 2 = 4 CV + 2 SV
<b>OUTPUT COMMANDS</b>						
F	OFMT	Output formats selection.	Rd/Wr	0	10	0 = VGA 60 Hz      6 = XGA 75 Hz 1 = SVGA 60 Hz      7 = D-ILA 4-3. 2 = XGA 60 Hz      8 = D-ILA 16/9 3 = SXGA 60 Hz      9 = 480p 4 = VGA 75 Hz      10 = 720p 5 = SVGA 75 Hz
fm	OSYN	MAIN output sync selection.	Rd/Wr	0	2	0 = Separate H & V sync. 2 = SOG 1 = Composite sync.
fp	osyn	PREVIEW output sync selection.	Rd/Wr	0	1	0 = Separate H & V sync. 1 = Composite sync.
fs	SCRN	Type of screen selection	Rd/Wr	0	1	0 = 4/3 screen      1 = 16/9 screen
pm	PAT	MAIN test pattern selection.	Rd/Wr	0	1	0 = OFF      1 = ON
pp	pat	PREVIEW test pattern selection.	Rd/Wr	0	1	0 = OFF      1 = ON
XR	REFR	Input synchronization selection.	Rd/Wr	0	21	0 = Internal rate.      17 = S.VIDEO1 rate. 1 = RGB/YUV1 rate.      21 = SDI input rate. 9 = COMPOSITE 9 rate.
ur	ADJR	Red level adjustment.	Rd/Wr	0	255	
ug	ADJG	Green level adjustment.	Rd/Wr	0	255	
ub	ADJB	Bleu level adjustment.	Rd/Wr	0	255	

**NOTE:** Rd = Read only command.

Rd/Wr = Read and write command.



10-4. COMMANDS AND RESPONSES TABLE (continued)

ASCII COMMAND	RESPONSE	COMMAND DESCRIPTION	TYPE	VALUE		
				MIN	MAX	DESCRIPTION
<b>IMAGE COMMANDS</b>						
QO	OVR	Underscan / overscan (MAIN)	Rd/Wr	0	1	0 = underscan 1 = overscan
qo	ovr	Underscan / overscan (PREVIEW)	Rd/Wr	0	1	0 = underscan 1 = overscan
A	ASP	Input aspect ratio selection (MAIN)	Rd/Wr	0	2	0 = 4/3 standard 1 = 16/9 letterbox 2 = 16/9 or WS anamorphic
a	asp	Input aspect ratio selection (PREV.)	Rd/Wr	0	2	Identical as A command
K	BLK	Black level adjustment (MAIN).	Rd/Wr	0	255	
k	blk	Black level adjustment (PREVIEW).	Rd/Wr	0	255	
B	BRG	Brightness adjustment (MAIN).	Rd/Wr	0	255	
b	brg	Brightness adjustment (PREVIEW).	Rd/Wr	0	255	
D	CON	Contrast adjustment (MAIN).	Rd/Wr	0	255	
d	con	Contrast adjustment (PREVIEW).	Rd/Wr	0	255	
O	COL	Color adjustment (MAIN).	Rd/Wr	0	255	
o	col	Color adjustment (PREVIEW).	Rd/Wr	0	255	
T	HUE	Hue adjustment (MAIN).	Rd/Wr	0	255	
t	hue	Hue adjustment (PREVIEW).	Rd/Wr	0	255	
QP	PRO	Image process adjustment (MAIN).	Rd/Wr	0	7	0 = level 1..... 7 = level 8.
qp	pro	Image process adjustment (PREVIEW)	Rd/Wr	0	7	Identical as QP command.
QF	QF	Optimize adjustment (MAIN).	Rd/Wr	0	255	
qf	qf	Optimize adjustment (PREVIEW).	Rd/Wr	0	255	
QH	QH	Horizontal smoothing (MAIN).	Rd/Wr	0	1	0 = OFF 1 = ON
qh	qh	Horizontal smoothing (PREVIEW).	Rd/Wr	0	1	0 = OFF 1 = ON
QV	QV	Vertical smoothing (MAIN).	Rd/Wr	0	1	0 = OFF 1 = ON
qv	qv	Vertical smoothing (PREVIEW).	Rd/Wr	0	1	0 = OFF 1 = ON
ym	PRES	PRESET (MAIN).	Rd/Wr	0	1	1 = PRESET action (automatic reset).
yp	pres	PRESET (PREVIEW).	Rd/Wr	0	1	1 = PRESET action (automatic reset).
<b>EFFECTS COMMANDS</b>						
E	EFF	Effect selection.	Rd/Wr	0	20	Please see value description (next section).
ed	EFD	Effect duration selection.	Rd/Wr	5	255	Please see value description (next section).
eh	EFH	Horizontal position of the effect.	Rd/Wr	0	255	
ev	EFV	Vertical position of the effect (PIP...)	Rd/Wr	0	255	
es	EFS	Vertical size of the effect (PIP, SHADOW...)	Rd/Wr	0	200	0 = 0 % 200 = 100 % (For PIP : MIN value = 30).
eH	EFs	Horizontal size of the PIP.	Rd/Wr	0	255	0 = 0 % 200 = 100 %
ex	EFx	Horizontal shape position (PIP) or Intensity (Shadow title).	Rd/Wr	0	255	
ey	EFy	Vertical shape position (PIP).	Rd/Wr	0	255	
eX	EFX	Horizontal shape size (PIP).	Rd/Wr	0	200	
eY	EFY	Vertical shape size (PIP).	Rd/Wr	0	200	
g	EON	Effect in progress.	Rd	0	1	0 = no effect in progress. 1 = effect in progress.
xC	ICHS	New background source during a POP.	Rd	0	21	Identical as c command.
<b>TALLY OUTPUTS COMMANDS</b>						
ja	TALA	Input number for TALLY1	Rd/Wr	1	21	Please see value description (next section).
jb	TALB	Input number for TALLY2.	Rd/Wr	1	21	Please see value description (next section).
jc	TALC	Input number for TALLY3.	Rd/Wr	1	21	Please see value description (next section).
jd	TALD	Input number for TALLY4.	Rd/Wr	1	21	Please see value description (next section).
JA	TAON	TALLY1 status.	Rd	0	1	0 = TALLY1 inactive 1 = TALLY1 active.
JB	TBON	TALLY2 status.	Rd	0	1	0 = TALLY2 inactive 1 = TALLY2 active.
JC	TCON	TALLY3 status.	Rd	0	1	0 = TALLY3 inactive 1 = TALLY3 active.
JD	TDON	TALLY4 status.	Rd	0	1	0 = TALLY4 inactive 1 = TALLY4 active.



10-4. COMMANDS AND RESPONSES TABLE (continued)

ASCII COMMAND	RESPONSE	COMMAND DESCRIPTION	TYPE	VALUE		
				MIN	MAX	DESCRIPTION
<b>STATUS COMMANDS</b>						
U	UNIT	Measures unity in kHz.	Rd	0	65535	
IL	ILD	Horizontal period of input signal (M)	Rd	0	65535	Please see value description (next section).
il	ild	Horizontal period of input signal (P)	Rd	0	65535	Please see value description (next section).
ID	IFD	Vertical period of input signal (M)	Rd	0	65535	Please see value description (next section).
id	ifd	Vertical period of input signal (P)	Rd	0	65535	Please see value description (next section).
IP	IPS	Input Sync. detection (MAIN).	Rd	0	1	0 = no Sync. detected 1 = Sync. detected.
ip	ips	Input Sync. detection (PREVIEW).	Rd	0	1	0 = no Sync. detected 1 = Sync. detected.
IH	IHP	Sign of the horizontal input Sync. (M)	Rd	0	1	0 = negative 1 = positive.
ih	ihp	Sign of the horizontal input Sync. (P)	Rd	0	1	0 = negative 1 = positive.
IV	IVP	Sign of the vertical input Sync. (M)	Rd	0	1	0 = negative 1 = positive.
iv	ivp	Sign of the vertical input Sync. (P)	Rd	0	1	0 = negative 1 = positive.
IK	IST	Input Sync type detection (MAIN).	Rd	0	3	0 = Separate H & V sync. 1 = Composite sync. (TTL). 2 = SOG (Sync. On Green). 3 = Composite sync. (analog).
ik	ist	Input Sync type detection (PREVIEW).	Rd	0	3	Identical as IK command.
II	IIN	Interlaced signal detection (MAIN).	Rd	0	1	0 = not interlaced 1 = interlaced.
ii	iin	Interlaced signal detection (P).	Rd	0	1	0 = not interlaced 1 = interlaced.
IO	IOO	"Out of range" signal detection (M).	Rd	0	1	0 = In range 1 = Out of range.
io	ioo	"Out of range" signal detection (P).	Rd	0	1	0 = In range 1 = Out of range.
IF	IFA	Standard input signal detection (M).	Rd	0	27	Please see value description (next section).
if	ifa	Standard input signal detection (P).	Rd	0	27	Please see value description (next section).
XR	REFR	Input synchronization selection.	Rd/Wr	0	21	0 = Internal rate 17 = S.VIDEO1 rate. 1 = RGB/YUV1 rate. 21 = SDI input rate. 9 = COMPOSITE 9 rate.
XA	REFA	Synchronized input status.	Rd	0	21	Identical as XR command.
XF	REFF	Standard of the referenced input.	Rd	0	27	Please see value description (next section).
XT	REFT	Frame frequency of the referenced input.	Rd	0	65535	Value in Hz.
<b>CONTROLS COMMANDS</b>						
yl	LOCK	FRONT PANEL locking.	Rd/Wr	0	31	1 = locks the INPUT SELECT keys. 2 = locks the ADJUST buttons. 4 = locks the EFFECT keys. 8 = locks the CONTROL keys. 16 = lock the FREEZE keys.
yc	EPOS	Erase all memories.	Rd/Wr	0	1	1 = erase all memories (automatic reset).
yd	DEMO	Demo mode.	Rd/Wr	0	1	0 = demo mode inactive. 1 = demo mode active.
xi	I	Identification number.	Rd	0	65535	Values displayed in hexadecimal in the GSW2811R.
xk	K_	"K" Firmware Version.	Rd	0	65535	
xx	X_	"X" Firmware Version.	Rd	0	65535	
xy	Y_	"Y" Firmware Version.	Rd	0	65535	
xs	S_	"S" Firmware Version.	Rd	0	65535	
xd	D_	"D" Firmware Version.	Rd	0	65535	
xa	A_	"A" Firmware Version.	Rd	0	65535	
xb	B_	"B" Firmware Version.	Rd	0	65535	
Y	FRES	DEFAULT VALUE.	Rd/Wr	0	1	1 = Default value action (automatic reset).
<b>OTHERS COMMANDS</b>						
L	CUT	CUT effect.	Rd/Wr	0	1	1 = CUT action (automatic reset).
N	TBP	T-BAR position.	Rd/Wr	0	255	
@	@	Percentage of the executed effect.	Rd	0	16383	0 = 0% 16383 = 100%
ua	TBA	T-BAR availability.	Rd	0	1	0 = T-BAR unavailable. 1 = T-BAR available.
?	DEV	Device type.	Rd	0	65535	12 = GSW2811R/GSE2811R.
#	DEV12	Send all device parameters.	Rd			



10-4. COMMANDS AND RESPONSES TABLE (continued)

ASCII COMMAND	RESPONSE	COMMAND DESCRIPTION	TYPE	VALUE		
				MIN	MAX	DESCRIPTION
<b>SEQUENCE MODE COMMANDS</b>						
el	SEQS	Function of the sequence mode.	Rd/Wr	0	5	Please see value description (next section).
ei	SEQV	Validation of the selected function.	Rd/Wr	0	1	Please see value description (next section).
er	SEQC	Current step selection.	Rd/Wr	1	40	Please see value description (next section).
ut	tkev	Status of the pre-selected input.	Rd	0	1	Please see value description (next section).
<b>VIDEO OUTPUT COMMANDS (OPTIONAL)</b>						
Qs	VSTD	Output video standard selection.	Rd/Wr	0	1	0 = NTSC            1 = PAL
Qf	VAF	Anti-flicker level selection.	Rd/Wr	0	2	0 = level 1            1 = level 2 2 = level 3
Qr	VREF	Reference signal of the video output.	Rd/Wr	0	2	0 = internal rate    1 = follow 2 = genlock.
Qv	VERV	Status of the video output version.	Rd	0	65535	
Qo	VOVR	Zoom mode selection.	Rd/Wr	0	1	0 = overscan        1 = underscan.
<b>ADD-ON-1 COMMANDS (OPTIONAL)</b>						
eS	EDGS	Size of the blending.	Rd/Wr	0	255	0 = 0%                255 = 50%
eA	EDGA	Position of the device in function of the screen.	Rd/Wr	0	255	bits 0-3: position of the device. bits 4-7: number of device for the screen.
eC	PEDG	Image cutting.	Rd/Wr	0	1	0 = inactive        1 = active.
eT	EDGT	Type of softedge	Rd/Wr	0	255	0 = no softedge.    1 = linear softedge bit 7 = active/inactive the softedge.
eP	EDPM	MAIN image position.	Rd/Wr	0	255	
eZ	EDZM	MAIN image size.	Rd/Wr	0	255	
ep	EDPP	PREVIEW image position.	Rd/Wr	0	255	
ez	EDZP	PREVIEW image size.	Rd/Wr	0	255	
eH	EFs	Horizontal size of the PIP.	Rd/Wr	0	255	
ek	EDFC	Softedge - Control point #1 (X)	Rd/Wr	1	63	
eK	EDSC	Softedge - Control point #2 (X)	Rd/Wr	1	63	
ej	EDFL	Softedge - Control point #1 (Y)	Rd/Wr	1	63	
eJ	EDSL	Softedge - Control point #2 (Y)	Rd/Wr	1	63	

10-5. VALUES DESCRIPTION TABLE

ASCII COMMAND	RESPONSE	COMMAND DESCRIPTION	VALUE DESCRIPTION			
C	CH	MAIN selected input (read only).	0	Black	11	COMPOSITE #11 input
			1	RGB/YUV #1 input	12	COMPOSITE #12 input
			2	RGB/YUV #2 input	13	COMPOSITE #13 input
			3	RGB/YUV #3 input	14	COMPOSITE #14 input
			4	RGB/YUV #4 input	15	COMPOSITE #15 input
			5	RGB/YUV #5 input	16	COMPOSITE #16 input
			6	RGB/YUV #6 input	17	S.VIDEO #1 input
			7	RGB/YUV #7 input	18	S.VIDEO #2 input
			8	RGB/YUV #8 input	19	S.VIDEO #3 input
			9	COMPOSITE #9 input	20	S.VIDEO #4 input
			10	COMPOSITE #10 input	21	SDI input
c	ch	Input pre-selection (PREVIEW).	Identical as C command.			
PC	PCH	Input selection for adjustment.	0	All inputs	11	COMPOSITE #11 input
			1	RGB/YUV #1 input	12	COMPOSITE #12 input
			2	RGB/YUV #2 input	13	COMPOSITE #13 input
			3	RGB/YUV #3 input	14	COMPOSITE #14 input
			4	RGB/YUV #4 input	15	COMPOSITE #15 input
			5	RGB/YUV #5 input	16	COMPOSITE #16 input
			6	RGB/YUV #6 input	17	S.VIDEO #1 input
			7	RGB/YUV #7 input	18	S.VIDEO #2 input
			8	RGB/YUV #8 input	19	S.VIDEO #3 input
			9	COMPOSITE #9 input	20	S.VIDEO #4 input
			10	COMPOSITE #10 input	21	SDI input



10-5. VALUES DESCRIPTION TABLE (continued)

ASCII COMMAND	RESPONSE	COMMAND DESCRIPTION	VALUE DESCRIPTION
E	EFF	Effect selection.	00 = CUT. 01 = FADING: automatic from 0.5 to 25 seconds or T-BAR. 02 = TITLE: automatic from 0.5 to 25 seconds or T-BAR. 03 = TITLE: holding. 04 = SHADOW TITLE: automatic from 0.5 to 25 seconds or T-BAR. 05 = SHADOW TITLE: holding. 06 = HOR WIPE, Left to Right: automatic from 0.5 to 25 sec or T-BAR. 07 = HOR WIPE, Right to Left: automatic from 0.5 to 25 sec or T-BAR. 08 = HOR WIPE, to Center: automatic from 0.5 to 25 seconds or T-BAR. 09 = HOR WIPE, from Center: automatic from 0.5 to 25 sec or T-BAR. 10 = VERT WIPE, Up: automatic from 0.5 to 25 seconds or T-BAR. 11 = VERT WIPE, Down: automatic from 0.5 to 25 seconds or T-BAR. 12 = VERT WIPE, to Center: automatic from 0.5 to 25 seconds or T-BAR. 13 = VERT WIPE, from Center: automatic from 0.5 to 25 sec or T-BAR. 14 = DIAMOND WIPE, to Center: automatic from 0.5 to 25 sec or T-BAR. 15 = DIAMOND WIPE, from Center: automatic from 0.5 to 25 sec or T-BAR. 16 = Normal PIP : automatic from 0.5 to 25 seconds or T-BAR. 17 = Normal PIP : holding. 18 = Fade PIP : automatic from 0.5 to 25 seconds or T-BAR. 19 = Fade PIP : holding. 20 = POP.
ed	EFD	Effect duration selection (from 0.5s to 25.5 seconds by 0.1s step).	5 = 0.5 second ... 255 = 25.5 seconds.
el	SEQS	Selection of a function of the sequence mode.	0 = no function selected. 1 = <b>add step</b> function. 2 = <b>play sequence</b> function. 3 = <b>list sequence</b> function. 4 = <b>erase last</b> function. 5 = <b>clear sequence</b> function.
ei	SEQV	Validation of the selected function.	1 = validate the selected function of the sequence mode (automatic reset). <b>For example:</b> • If <b>add step</b> selected, this command add a step into your sequence. • If <b>erase last</b> selected, this command erases the last step of your sequence.
er	SEQC	Current step selection.	1 = select step # 1. ..... 40 = select step # 40.
ut	tkev	Status of the pre-selected input (read only).	The command indicates if the pre-selected input is ready to commute or not. 0 = pre-selected input not ready to commute. The validation of the selected function can not be activate. 1 = pre-selected input ready to commute. The validation of the selected function can be activate.
ja	TALA	Input number for TALLY1	Identical as C command.
jb	TALB	Input number for TALLY2	Identical as C command.
jc	TALC	Input number for TALLY3	Identical as C command.
jd	TALD	Input number for TALLY4	Identical as C command.
IL	ILD	This command allows to calculate the input line frequency in Hz (MAIN).	Line frequency (in kHz) = (UNIT VALUE) ÷ (ILD VALUE).
il	ild	This command allows to calculate the input frame frequency in Hz (PREV).	Line frequency (in kHz) = (UNIT VALUE) ÷ (ild VALUE).
ID	IFD	This command allows to calculate the input frame frequency in Hz (MAIN).	Frame frequency (in Hz) = (Line frequency in Hz) ÷ (IFD VALUE).

10-5. VALUES DESCRIPTION TABLE (continued)

ASCII COMMAND	RESPONSE	COMMAND DESCRIPTION	VALUE DESCRIPTION
id	ifd	This command allows to calculate the input frame frequency in Hz (PREV).	Frame frequency (in Hz) = (Line frequency in Hz) ÷ (ifd VALUE).
IF	IFA	Input standard detection (MAIN).	0 = no signal 1 = "out of range" signal <b>2 = NTSC std (3.58 / 60)</b> 3 = NTSC (3.58 / 50) 4 = NTSC (4.43 / 60) 5 = NTSC (4.43 / 50) 6 = PAL M (3.58 / 60) 7 = PAL comb (3.58 / 50) 8 = PAL (4.43 / 60) <b>9 = PAL std (4.43 / 50)</b> <b>10 = SECAM (50Hz)</b> 11 = Black and white (50Hz) 12 = Black and white (60 Hz) 13 = YUV 50 Hz 14 = YUV 60 Hz 15 = RGB 50 Hz 16 = RGB 60 Hz 17 = VGA1 350L 18 = VGA2 400L 19 = VGA3 480L 20 = PLASMA 42" 21 = SVGA 22 = MAC 23 = XGA 24 = PLASMA 50' 25 = MAC 21' 26 = SXGA 27 = UXGA
if	ifa	Input standard (PREVIEW)	Identical as IF command.
XF	REFF	Standard of the referenced input (read only).	Identical as IF command.

10-6. ASCII / HEX / DEC TABLE

ASCII	HEX	DEC	ASCII	HEX	DEC	ASCII	HEX	DEC
space	20	32	@	40	64	`	60	96
!	21	33	A	41	65	a	61	97
"	22	34	B	42	66	b	62	98
#	23	35	C	43	67	c	63	99
\$	24	36	D	44	68	d	64	100
%	25	37	E	45	69	e	65	101
&	26	38	F	46	70	f	66	102
'	27	39	G	47	71	g	67	103
(	28	40	H	48	72	h	68	104
)	29	41	I	49	73	i	69	105
*	2A	42	J	4A	74	j	6A	106
+	2B	43	K	4B	75	k	6B	107
,	2C	44	L	4C	76	l	6C	108
-	2D	45	M	4D	77	m	6D	109
.	2E	46	N	4E	78	n	6E	110
/	2F	47	O	4F	79	o	6F	111
0	30	48	P	50	80	p	70	112
1	31	49	Q	51	81	q	71	113
2	32	50	R	52	82	r	72	114
3	33	51	S	53	83	s	73	115
4	34	52	T	54	84	t	74	116
5	35	53	U	55	85	u	75	117
6	36	54	V	56	86	v	76	118
7	37	55	W	57	87	w	77	119
8	38	56	X	58	88	x	78	120
9	39	57	Y	59	89	y	79	121
:	3A	58	Z	5A	90	z	7A	122
;	3B	59		5B	91	{	7B	123
<	3C	60	\	5C	92		7C	124
=	3D	61		5D	93	}	7D	125
>	3E	62	^	5E	94	~	7E	126
?	3F	63	_	5F	95	DEL	7F	127





**Chapter 11 : TECHNICAL SPECIFICATIONS**

**RGB/YUV INPUTS**

• **COMPUTER FORMATS (PC, MAC , Workstation).**

*Hardware Compatibility:* Line frequency : From 31.5 kHz to 130 kHz.  
 Resolutions : From 640 x 480 to 1600 x 1280.  
 Sync : Separate H & V, COMP, SOG.

*Levels:* R, G, B = 3 x 0.7 Vp/p.  
 H & V Sync. = TTL.  
 Composite sync = TTL and 0.3 V.  
 SOG (Sync. On Green) = 0.3 V.

*Impedance:* R, G, B = 75 ohms.  
 H = Hi-Z or 75 ohms.  
 V = 75 ohms.

• **VIDEO FORMATS**

• **RGB/S (on 4 BNC connectors).**

15.625 kHz / 50 Hz .... 15.735 kHz / 60 Hz (625L .....525L).

*Levels:* R, G, B = 3 x 0.7 Vp/p.  
 Sync. = 0.3 V or TTL.

*Impedance:* RGB = 75 ohms.  
 Sync. = 75 ohms or Hi-Z.

• **Y DR DB (R-Y / Y / B-Y) COMPONENT (on 3 BNC connectors).**

15.625 kHz / 50 Hz .... 15.735 kHz / 60 Hz (625L .....525L).

*Levels:* Y = 1 Vp/p (0.7 V luma + 0.3 V sync).  
 Dr = 0.7 Vp/p.  
 Db = 0.7 Vp/p.

*Impedance:* Y, Dr, Db = 75 ohms.

• **HDTV FORMATS**

• **720p & 1080i**

*Levels:* R, G, B = 3 x 0.7 Vp/p.

*Sync.:* H & V Sync. = TTL (Bi-level).

*Impedance:* 75 Ohms.

**COMPOSITE & S.VIDEO INPUTS**

• **S.VIDEO (on 2 BNC connectors).**

PAL / SECAM 15.625 kHz / 50 Hz (625L)  
 NTSC 3.58 MHz / 4.43 MHz 15.735 kHz / 60 Hz (525L)

*Levels:* Y = 1 Vp/p (0.7 V luma + 0.3 V sync).  
 C = 0.3 Vp/p (chroma burst).

*Impedance:* 75 ohms.

• **COMPOSITE VIDEO (on 1 BNC connector)**

PAL / SECAM 15.625 kHz / 50 Hz (625L)  
 NTSC 3.58 MHz / 4.43 MHz 15.735 kHz / 60 Hz (525L)

*Level:* 1 Vp/p (0.7 V luma + 0.3 V sync).

*Impedance:* 75 ohms.

**SDI INPUT** (Optional input on BNC connector).

*Signal:* Component (4:2:2) serial digital input conforming to SMPTE-259M.  
*Data rate:* 270 Mbps.

**MAIN & PREVIEW OUTPUTS**

• **MAIN (on BNC & HD15 female connectors)**

*Levels:* R, G, B = 3 x 0.7 Vp/p.  
 Separate H & V Sync. = TTL.  
 Composite Sync = TTL.  
 SOG = 0.3 Vp/p.

*Impedance:* 75 ohms.

*Resolution:* One of the available resolutions in the LCD screen menus.

• **PREVIEW (on HD 15 female connector)**

*Levels:* R, G, B = 3 x 0.7 Vp/p.  
 Separate H & V Sync. = TTL.  
 Composite Sync = TTL.

*Impedance:* 75 ohms.

*Resolution:* One of the available resolutions in the LCD screen menus.

**REMOTE PORT & TALLY OUT**

• **REMOTE RS-232 (on DB 9 female connector)**

*Level:* RS-232.  
*Data Rate:* 9600 Bauds, 8 data bits, 1 stop bit, no parity bit, no flow control.

• **TALLY OUT (on DB 9 female connector)**

*Rating:* 20 Vdc, 50 mA (open collector).

PIN #	FUNCTION
1	tally # 1
2	Tx (transmit data)
3	Rx (receive data)
4	NC
5	Ground
6	tally # 2
7	tally # 3
8	NC
9	tally # 4

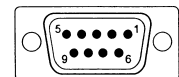

**DB9 Female connector**

**OPTIONAL VIDEO OUTPUT**

• **COMPOSITE VIDEO (on BNC connector)**

PAL / SECAM 15.625 kHz / 50 Hz (625L)  
 NTSC 3.58 MHz / 4.43 MHz 15.735 kHz / 60 Hz (525L)

*Level:* 1 Vp/p (0.7 V Luma + 0.3 V Sync.).

*Impedance:* 75 ohms.

• **S.VIDEO (on DB9 connector)**

PAL / SECAM 15.625 kHz / 50 Hz (625L)  
 NTSC 3.58 MHz / 4.43 MHz 15.735 kHz / 60 Hz (525L)

*Levels:* Y = 1 Vp/p (0.7 V Luma + 0.3 V Sync.).  
 C = 0.3 Vp/p (chroma burst).

*Impedance:* 75 ohms.



**OPTIONAL VIDEO OUTPUT (continued)**

• **Y DR DB (R-Y / Y / B-Y) COMPONENT (on DB9 connector).**

15.625 kHz / 50 Hz .... 15.735 kHz / 60 Hz (625L .....525L).

*Levels:* Y = 1 Vp/p (0.7 V luma + 0.3 V sync).  
 Dr = 0.7 Vp/p.  
 Db = 0.7 Vp/p.

*Impedance:* Y, Dr, Db = 75 ohms.

• **DB9 PIN ASSIGNMENT**

PIN #	FUNCTION
1	RTN
2	(red, green, bleu, genlock)
3	RED (R-Y)
4	GREEN (Y)
5	BLEU (B-Y)
6	Y (S.VIDEO)
7	genlock
8	RTN (Y+C)
9	C (S.VIDEO)

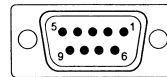

DB9 Female connector

**ENVIRONMENTAL**

*Power Supply:* Internal CE / UL / CSA / IEC 950 (130W).  
 Input : 100VAC to 240VAC ; 50-60Hz ; I = 3A Max.

*Storage Temperature:* -25 °C to +85 °C (-13 °F to +185 °F).

*Operating temperature:* 0 °C to 50 °C (32 °F to 122 °F).

*Maximum ambient operating temperature:* < 40 °C ( < 104 °F).

*Hygrometry:* 10% to 80% (without condensation).

*Dimension:* W 480 x D 340 x H 133mm / 19"W x 13.4"D x 5.2"H.  
 (Compatible with a Standard 19" rack, Height = 3 U).

*Weight:* 9 kg / 20 lbs. (without option)  
 9.5 kg / 21 lbs. (with the SDI (-D1) or the OPT-GSW2-VO option).  
 10 kg / 22 lbs. (with the SDI (-D1) and the OPT-GSW2-VO options).

## **WARRANTY**

Analog Way warrants the product against any defects in materials and workmanship for a period of three years from the date of purchase (back to the factory).

In the event of any malfunction during the warranty period, Analog Way will, at its discretion, repair or replace the defective units, including free materials and labor.

This warranty does not apply if the product has been :

- improperly installed or abused,
- handled with improper care,
- used or stocked in abnormal conditions,
- modified, opened,
- damaged by fire, war, or Natural disasters (Acts of God).

In no way shall Analog Way be responsible for direct or indirect loss of profit or consequential damages resulting from any defect in this product.

In case of any problem, get the serial number of the unit, a description of the problem, and then call your authorized dealer.